

T+A

Owner`s Manual

MP 8



Welcome.

We are delighted that you have decided to purchase a **T+A** product. With your new **MP 8** you have acquired a top-quality piece of equipment which has been designed and developed with the wishes of discerning listeners as absolute top priority.

This system represents our very best efforts at designing practical electronic equipment incorporating solid quality, user-friendly operation and a specification and performance which leaves nothing to be desired.

All these factors contribute to a piece of equipment which will satisfy your highest demands and your most searching requirements for a period of many years. All the components we use meet the German and European safety norms and standards which are currently valid. All the materials we use are subject to painstaking quality monitoring.

At all stages of production we avoid the use of substances which are environmentally unsound or potentially hazardous to health, such as chlorine-based cleaning agents and CFCs.

We also aim to avoid the use of plastics in general, and PVC in particular, in the design of our products. Instead we rely upon metals and other non-hazardous materials; metal components are ideal for recycling, and also provide effective electrical screening.

Our robust all-metal cases exclude any possibility of external sources of interference affecting the quality of reproduction. From the opposite point of view our products' electro-magnetic radiation (electro-smog) is reduced to an absolute minimum by the outstandingly effective screening provided by the metal case.

Our range of accessories includes high-quality cables and connectors

We would like to take this opportunity to thank you for the faith you have shown in our company by purchasing this product, and wish you many hours of enjoyment and sheer listening pleasure with your **MP 8**.

T+A elektroakustik GmbH & Co KG

License Notice

This product contains software in form of object code that is partially based on free software under different licenses, especially the GNU General Public License. You can find details on this in the License Information which you should have received with this product.

If you have not received a copy of the GNU General Public License, please see <http://www.gnu.org/licenses/>.

For a period of three years after last distribution of this product or its firmware, T+A offer the right to any third party to obtain a complete machine-readable copy of the corresponding source code on physical storage medium (DVD-ROM or USB stick) for a charge of 20€. To obtain such copy of the source code, please write to the following address including information about product model and firmware version: **T+A elektroakustik, Planckstr. 9-11, 32052 Herford, Germany.**

It is also possible to retrieve the used licenses directly from the device with the help of an Internet browser. For details, see the chapter entitled "**Legal Information**".



HD Radio Technology manufactured under license from iBiquity Digital Corporation. U.S. and Foreign Patents. HD Radio™ and the HD, HD Radio, and "Arc" logos are proprietary trademarks of iBiquity Digital Corp.

* HD Radio™ technology only available in US-version



Symbols on the back panel



The CE symbol on the device declares conformity with the EC directives and the national laws derived from them.



For operation at altitudes up to 2000 m above sea level.



For operation in temperate climate. Permissible operating temperature range +10 ... +35 C.



The device must not be disposed of with normal household waste. Local collection points for electrical waste are available for the subsequent disposal of this product.

About these instructions

All the controls and functions of the **MP 8** which are frequently used are described in the first section of these operating instructions.

The second part '**Basic settings, Installation, Using the system for the first time**' covers connections and settings which are very seldom required; they are generally required only when the machine is set up and used for the first time. Here you will also find a detailed description of the network settings required for connecting the **MP 8** to your home network.

Symbols used in these instructions



Caution!

Text passages marked with this symbol contain important information which must be observed if the machine is to operate safely and without problems.



This symbol marks text passages which provide supplementary notes and background information; they are intended to help the user understand how to get the best out of the machine.

Notes on software updates

Many features of the **MP 8** are software based. Updates and new features will be made available from time to time. The update process takes only a few minutes. See the chapter entitled "Software update" for how to update your device via the internet connection.

We recommend you to check for updates before using your **MP 8** for the first time. To keep your device up to date you should check for updates from time to time.



The operation instructions, the connection guidance and the safety notes are for your own good - please read them carefully and observe them at all times. The operating instructions are an integral part of this device. If you ever transfer the product to a new owner please be sure to pass them on to the purchaser to guard against incorrect operation and possible hazards.



All the components we use meet the German and European safety norms and standards which are currently valid. This product complies with the EU directives. The declaration of conformity can be downloaded from **www.ta-hifi.com/DoC**.

Contents

Front panel controls	8
Remote control	14
Charging the remote control handset	16
Operation with the App or the FM1000	16
Basic settings of the MP 8	17
Calling up and operating the menu	17
Source names	17
Display brightness	18
Display mode	18
Language	18
Device name	18
Network	18
Music services.....	19
Bandwidth limit	19
Energy saver	19
Device Info	20
Operating the sources in detail	21
Favourites lists	21
General information.....	21
Adding a favourite	21
Calling up the Favourites list	21
Erasing a favourite from the Favourites list.....	22
Selecting a favourite from the list.....	22
Sorting Favourites lists	22
Operating the radio	24
FM - Radio	24
Selecting FM radio	24
General	24
Automatic station search	25
Selecting a station from the Station list	25
Selecting an HD Radio station	25
RDS functions	26
Switching Radio Text on and off	26
Mono / Stereo.....	26
DAB - Radio	26
Selecting DAB radio	26
Display	26
Automatic station search	27
Selecting a station from the Station list	27
RDS functions	28
Internet-Radio and podcasts	28
Selecting Internet Radio as source	28
Selecting podcasts	28

Playback	28
Favourites lists	29
Search function	29
Operating music services	30
General information.....	30
Selecting the music service	30
Playback	30
Search function	31
Playlists and favourites	31
Operating the UPnP source	32
General information on the streaming client	32
Selecting the UPnP source	32
Playback	32
Playback of directories	33
Playback with 	33
General information	33
Playback	33
Playing USB memory media	34
General information.....	34
Selecting USB Media as source	34
Playback	34
Playback of directories	35
Operating the Bluetooth source	36
Selecting Bluetooth	36
Setting up audio transfer	36
Playback functions	36
Notes	37
Operating the Disc player	38
Selecting CD as source	38
Inserting a CD	38
Playing a CD.....	38
Variations	39
Track Select.....	39
During playback	39
CD Text.....	39
Playback mode	39
Playback Program.....	40
Creating a playback program	40
Playing a playback program	40
Erasing a playback program.....	40
Installation, Using the system for the first time, Safety notes ..	41
Back panel connections.....	42
Installation and wiring	44

Safety notes	46
Network Configuration	49
The Configuration for a Wired Ethernet LAN or Power-Line LAN connection	51
Setting the Parameters for a Wired Network	51
The Configuration for a WLAN connection	53
Setting the parameters for a wireless network	53
Selecting and connecting a WLAN by hand	53
Searching for and Selecting the Network	53
Entering the Password (for encoded networks)	53
Storing Network Settings and Restarting	54
Connecting to WLAN via the WPS-function	54
WPS-function	54
Connecting WLAN automatically via the WPS function	54
Selecting the WLAN manually and connecting via WPS	54
WLAN setup via access point	55
Trouble shooting	56
Software update	58
Software update generally	58
Updating via the Internet	58
Notes on Energy Saving	59
General information	59
Automatic power-down (Energy saver)	59
Legal Information	59
General information	59
Show licenses	59
Appendix A	60
Wiring diagram	60
Wiring diagram	61
Appendix B	62
Specification	62

IMPORTANT! CAUTION!

This product contains a laser diode of higher class than 1. To ensure continued safety, do not remove any covers or attempt to gain access to the inside of the product. Refer all servicing to qualified personnel.

The following caution labels appear on your device:

Rear Panel:



Front panel controls

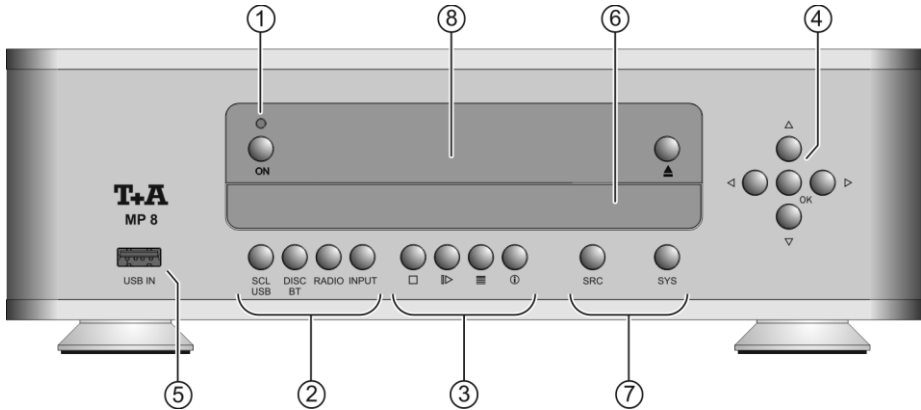

All the important functions of the **MP 8** can be operated using the buttons on the front panel. Direct-acting buttons are provided for fundamental functions. Functions not needed so frequently are controlled using menus which are called up using the **SYS** and **SRC**-button. The following section explains the functions of the buttons on the machine, and the information provided on the screen.

① On / Off switch



(On / Off switch)

A brief press on the **ON**-button switches the unit on and off.



Caution!

The mains button is not a mains isolation switch. Even when the LED is not glowing, some parts of the machine are still connected to mains voltage. The device can be only disconnected from the mains completely by withdrawing the mains plug from the wall socket.

② Source selection



Selects the **SCL**-function (e.g. access to music servers, streaming services or similar) or the **USB Media** function (connected USB memory media) of the streaming client. Press this button repeatedly until the desired source appears on the screen.



Selects the **CD player** or the **Bluetooth** function of the **MP 8**. Press this button once or twice until the desired source appears on the screen.



Selects one of the following radio sources: **FM / VHF** (FM RADIO source), **DAB** (DAB RADIO source), **Internet radio** (INTERNET RADIO source) or **Podcasts**. Press this button repeatedly until the desired source is displayed on the screen.



A brief press on this button selects the digital input you wish to use. Press the button repeatedly until the desired input is displayed on the screen.

③ Playback



Ends playback



During menu navigation:

A brief press takes you back (higher) by one menu level or aborts the current input process; the change is then abandoned.



Starts playback / halts playback (pause) / resumes playback after a pause



Calls up the Favourites list



Brief press:

- Cycles through the various screen displays.

Detailed display with / without CD text / Radiotext (if present) and large display with / without CD text / Radiotext (if present).

- Switches between capitals and lower case, and numeric / letters, when entering data.

Long press:

- When necessary, repeated long presses of the button cycle through the various playback modes (repeat track, repeat whole disc, etc.).

For details see chapter entitled “**Operating the disc player**”.

④ Navigation



Brief press

- Returns to the previous point / change button
- Returns from the play screen back to list navigation.

Long press during playback

- Rewind to search for a particular passage.
-



Brief press

- Confirms the input / change button.

Long press during playback

- Fast-forward to search for a particular passage.
-



Selects the next point within a list / select button
Selects the next track / station during playback.



Selects the previous point within a list / select button
Selects the previous track / station during playback.



Confirmation button during input procedures

⑤ USB-input

USB IN

Socket for a USB memory stick or an external hard disc.

The storage medium can be formatted with the FAT16, FAT32, NTFS, ext2, ext3 or ext4 file system.



The USB storage medium can be powered via the USB socket provided that its current drain meets the USB norm (< 500 mA). Normalised 2.5" USB hard discs can be connected directly to this socket, i.e. they require no mains PSU.



This socket can be used to recharge the battery in the **FM8**. Also possible if the **MP 8** is in stand-by mode.

⑥ CD drawer

The CD drawer is located below the display. Please insert the disc with the label side facing upwards into the appropriate depression of the tray.



The drawer is opened and closed by pressing the  button.

⑦ Settings



System configuration

Opens the “**System configuration**” menu (for details see Chapter “**System settings**”)



Source configuration

Opens the setup menu for the source device just selected.



Not all sources have their own setup menu. For this reason the button does not have a function with all sources.

⑧ Display

Display

All information relating to machine status, the current music track and list navigation is displayed on the graphic screen of the **MP 8**. The display is context-sensitive, and in part varies according to the capabilities and facilities of the service to which you are currently listening.

The most important information is highlighted on the screen according to context. Supplementary information is provided by symbols above and below the main data.

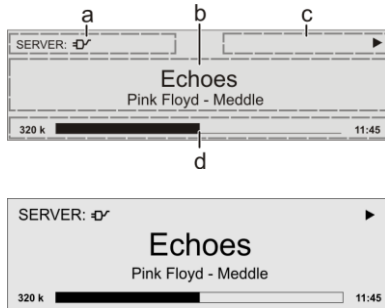

The displays and symbols which appear on the screen vary according to the currently active function.

The basic areas of the screen:

- Display field (a) shows the currently active source.
- Display field (b) shows information relating to the piece of music being played. The essential information is displayed enlarged in the main line.
- Display field (c) shows information relating to the device and playback.
- The bottom line (d) displays supplementary context-sensitive information (e.g. sampling frequency, elapsed time)













The **MP 8** features different display views for the playback of the sources.

- **Large-format display:**
Enlarged display of the most important information, clearly legible even from a distance
- **Detail display:**
Small-text display showing a large number of additional information points, e.g. bit-rate etc.

A brief press on the -button on the remote control handset is used to switch between the two display modes.

For the sources FM Radio and Disc, the radio and CD text (if available) are also turned on and off (cycles through the different modes) with this button.

Screen symbols and their meaning

	Making connection (Wait / Busy) The rotating symbol indicates that the MP 8 is currently processing a command, or is attempting to connect to a service. These processes may take some time to complete depending on the speed of your network and the load upon it. During such periods the MP 8 may be muted, and may not respond to the controls. Please wait until the symbol disappears, then try again.
	Indicates a music track which can be played , or a playlist .
	Indicates a folder which conceals further folders or lists.
	Indicates that a source is being reproduced via a cable connection .
	Indicates that a source is being reproduced via a radio connection .
	Indicates that the MP 8 is reproducing a station or playing back a music track.
	Pause indicator
	Buffer display (fullness indicator, memory display) and data rate indicator (if available): The higher the data rate, the better the quality of reproduction.
	Display of the elapsed playback time. This information is not available for all services.
	Indicates that the  -button can be used to switch to a higher menu or select level.
0 / 0	Position indicator in select lists. The first number shows the current position in the list, the second number the total number of list entries (length of list).
ABC abc 123	or or Display of the symbol input modes

Remote control

Introduction

The infrared receiver for the remote control handset is located left of the screen area. There must be line of sight contact between the **FM8** and the screen.









The following tables show the remote control buttons and their function when operating the machine.

i The illustration shows only those buttons which are required to control the **MP 8**. The buttons not shown are needed to operate the equipment in conjunction with a **DAC 8 DSD**.



	Switches the machine on and off
*	Selects the SCL function (e.g. access to music servers, streaming services or similar) or the USB Media function (connected USB memory media) of the streaming client. Press this button repeatedly until the desired source appears on the screen.
*	Selects the CD player or the Bluetooth function of the MP 8 . Press this button once or twice until the desired source appears on the screen.
*	Selects one of the following radio sources: FM / VHF (FM RADIO source), DAB (DAB RADIO source), Internet radio (Internet radio source) or Podcasts . Press this button repeatedly until the desired source is displayed on the screen.
*	A brief press on this button selects the digital input you wish to use. Press the button repeatedly until the desired input is displayed on the screen.
	Rocker button for source selection. Briefly press this button (+ or -) until the desired source appears on the screen.
	Brief press: <ul style="list-style-type: none"> - Opens the "System configuration menu" - (see chapter entitled "Basic settings of the MP 8") Long press: <ul style="list-style-type: none"> - Opens the Source menu - (not available for all sources)

* Only possible when the **MP 8** is operated stand-alone. When the **MP 8** is used in combination with a **DAC 8 DSD**, these buttons select the desired input on the **DAC 8 DSD**. In this case the source is selected on the **MP 8** using the buttons only. (see above)

	<p>Brief press:</p> <ul style="list-style-type: none"> - Confirmation button in lists and menus - Starts playback - Pauses current playback - Resumes playback after a pause <p>Long press:</p> <ul style="list-style-type: none"> - In menus: one level higher - In menus: interrupts current input - Stops playback - Opens and closes the CD drawer when the disc is stopped.
	<p>Selects the next point within a list / select button Selects the next track / station during playback.</p>
	<p>Selects the previous point within a list / select button Selects the previous track / station during playback.</p>
	<p>Returns to the previous point / change button Returns to list navigation while playback</p>
	<p>Confirms the input / change button</p>
	<p>Brief press:</p> <ul style="list-style-type: none"> - Cycles through the various screen displays. - Detailed display with / without CD text / Radiotext (if present) and large display with / without CD text / Radiotext (if present). - Switches between capitals and lower case, and numeric / letters, when entering data. <p>Long press:</p> <ul style="list-style-type: none"> - When necessary, repeated long presses of the button cycle through the various playback modes (repeat track, repeat whole disc, etc.). <p>For details see chapter entitled “Operating the disc player”.</p>
	<p>Brief press</p> <ul style="list-style-type: none"> - Calls up the Favourites list stored on the MP 8. <p>Long press</p> <ul style="list-style-type: none"> - Switches between stereo and mono reception during radio playback (FM Radio source only). <p>The Stereo setting is constantly displayed in the screen window by a  symbol. The Mono setting is constantly displayed in the screen window by a  symbol.</p>



Brief press

- Adds a favourite to the Favourites list.
- **CD - player:** Activates playback programming
Adds a track to the playback program during playback programming

Long press

- Removes a favourite from the Favourites list.
- **CD - player:** Erases the playback program.

Charging the remote control handset

The **FM 8** is fitted with an internal rechargeable battery (Li-Ion battery) which cannot be removed or replaced by the user. The battery in the remote control handset is automatically recharged when it is connected to the **USB IN** socket of the **MP 8** using the USB lead supplied in the set. The LED on the remote control handset flashes red when charging is in progress. The LED lights a solid red when the battery is fully charged.



The **FM8** cannot be used to control the **MP 8** when the battery is charging.



Do not charge the **FM8** unsupervised and make sure that the remote control is not too cold for charging (e.g. after transport etc.) The temperature of the remote control must be between 10°C and 30°C, if necessary let the FM8 warm up at room temperature, otherwise there is a danger of explosion!

Operation with the App or the FM1000



An even more convenient method of controlling the **MP 8** is to use the **T•A** 'TA Control' App.

As a further alternative the **MP 8** can be operated using the **FM1000** remote control handset which is available as an accessory. This includes additional features such as a numeric keypad for entering numbers.

Information on this can be found on our website at: www.ta-hifi.com

**For Apple
(iOS)**



For Android



Basic settings of the MP 8

(System Configuration menu)

The System Configuration menu is used for adjusting the general settings of the machine. This menu is described in detail in the following chapter.

Calling up and operating the menu

- Briefly press the **sys** -button on the front panel or the **☒** -button on the remote control handset to call up the menu.
- When the menu is opened, the screen displays the following Select points:

Adjustment facility	
Source names	Configuration
Display brightness	1 ... 7
Display mode	Always on Temporary Always off
Language	Deutsch English Francaise further languages
Device name	MP 8
Energy saver	On Off
Network	Configuration
Musik services	Configuration
Bandwidth limit	No limit 2000 kbps 500 kbps
Device info	Display

- Use the **▲** / **▼** buttons to select a point in the menu.
- If you wish to change the selected menu point, first press the **▶|OK** / **OK** -button, then use the **◀** / **▶** -buttons to alter the value.
- To accept the setting once you have changed the value, press the **▶|OK** / **OK** -button again.
- A long press on the **▶|OK** / **■** button also takes you back (higher) by one menu level.
- You can press the **▶|OK** / **■** button at any time to interrupt the process; the change is then abandoned.
- Press the **☒** / **sys** -button again to leave the menu.









Source names menu item



At this menu item you can activate and disable external sources, and assign a plain text name to each source; this name then appears in the screen displays.

When you call up this menu item using the **▶|OK** / **OK** -button, a list of all the external sources of the **MP 8** appears. Each source is followed by the assigned name, or if you have disabled the source concerned the note “disabled”.

To activate a source, press the **Ⓢ** button on the **FM8**; a long press on the **Ⓢ** button disables the source.

To change the plain-text name, move to the appropriate line and press the **▶|OK** / **OK** -button.

Change the name to your choice using the  /  /  /  buttons on the **FM8**, and confirm with . This action stores the settings for that source. The  / -button is used to switch between numeric and alpha-numeric input, and between capitals and lower-case letters. Letters can be erased by pressing the -button.

If you should wish to restore the factory default source name, erase the whole name before saving the empty field with the  / -button: this action resets the display to the standard source names.

Display brightness menu item

At this point you can adjust the brightness of the integral screen to suit your personal preference for normal use; eight levels are available.



We recommend that brightness settings 7 and 8 should only be used when the screen is difficult to read due to very bright ambient light. A lower brightness setting will extend the useful life of the screen.



Display mode menu item

This menu item offers the choice between three different display operation modes:

- Always on
- Temporary
- Always off

Selecting 'Temporary' will switch the display is on for a short while each time the **MP 8** is being operated. Shortly after operation the display will be switched off again automatically.



To switch the display on again, from the "always off" setting, call up the system settings menu by a brief press on the -button on the **FM8** or the -button on the **MP 8's** front panel.

Language menu item

In this menu point it is possible to determine the language which is to be used for the displays on the integral screen on the front panel of the **MP 8**.



The language used for any transferred data, e.g. from an Internet radio station, is determined by the device itself or the radio station, and therefore **cannot** be selected on the **MP 8**.

Device name menu item





This menu point can be used to assign an individual name to the **MP 8**. In a home network the device then appears under this name.

Network menu item



All network settings can be carried out at this menu point. For a detailed description on setting up a LAN or WLAN connection please also refer to the section entitled "**Network configuration**".

Music services
menu item



At this point you can enter the access data for the music streaming services (TIDAL etc.) supported by the **MP 8**.



Calling up this menu point by pressing the  / -button displays a list. Select the service you wish to use, then confirm your choice with the  / -button.



Now use the  /  /  /  buttons on the **FM8** to enter your access data in the lines "**Username**" and "**Password**"; this data is provided by your service provider.

Use the  / -button to switch between numeric and alphanumeric data entry, and between capitals and lower case.

Press the -button to erase a letter.

When you have entered your username and password confirm each step by pressing the  / -button.

To conclude the procedure and save the data, select the menu entry "**Store and exit?**" and confirm by pressing the  / -button.

To conclude the procedure and save the data, select the menu entry "**Store and exit?**" and confirm by pressing the  / -button.

 If access data for the selected music service has already been stored, the new data will overwrite them. To use the new access data you must first perform a "Logout" for the service in question, then switch the **MP 8** off and on again.

 The music streaming services supported by the **MP 8** require a subscription to the appropriate service provider.

Bandwidth limit
menu item

This menu point can be used to adjust the link speed of the Internet connection. The bitrate of the Internet radio stations and streaming services is adjusted automatically to match your chosen setting. If you select "**no limit**" for bandwidth limit, the highest available quality is always selected automatically.

 If you do not know the exact bandwidth of the internet connection, we recommend that you select the setting at which no drop-outs occur during playback.

Energy saver
(Stand-by mode)
menu item

The **MP 8** features two stand-by modes: ECO Standby with reduced stand-by current drain, and Comfort Standby with additional functions, but slightly higher current drain. You can select your preferred stand-by mode in this menu point:

On (ECO Standby)

Active functions in ECO Standby mode:

- Can be switched on by remote control
- Automatic power down function after 90 minutes without signal

Off (Comfort-Standby)

The following expanded functions are available:

- Can be switched on by App
- Automatic power down function off

Device Info
menu item

At this menu point you will find information on the status of the installed software and the factory reset.

Sub-point
Update

At this point it is possible to initiate a firmware update. The update can be accessed from an Internet connection.

Sub-point
Update package

This point displays the currently installed software package.

Sub-point
Control

Display of the control software version

Sub-point
Client

Display of the Streaming Client software version

Sub-point
DAB / FM

Display of the tuner software version.

Sub-point
Decoder

Display of the CD mechanism decoder software

Sub-point
Default settings

Calling up and confirming this menu point erases all personal settings, and restores the machine to the state as delivered (factory defaults).

Sub-point
Legal information

Calling up and confirming this menu point erases all personal settings, and restores the machine to the state as delivered (factory defaults).



For further information, see the chapter entitled "Legal Information".

Operating the sources in detail

Favourites lists

General information

The **MP 8** includes the facility to create Favourites lists. The purpose of these lists is to store radio stations, so that they can be accessed swiftly. Each of the sources **FM radio**, **DAB radio**, and **Internet radio** features its own Favourites list.

Once stored, the favourites can be selected from the Favourites list.

i Favourites lists for the various music services (TIDAL etc.) are not supported.

Instead it is usually possible to add Favourites and Playlists on-line via the provider's account. These can then be called up and played via the **MP 8**.

Adding a favourite

If you especially enjoy the piece of music or radio station to which you are currently listening, simply press the **(📶📻)** button on the **FMB**; this action stores the station in the corresponding Favourites list.

i Each Favourites lists features 99 program locations. Favourites lists can only be used to store the piece of music and station which is currently playing.



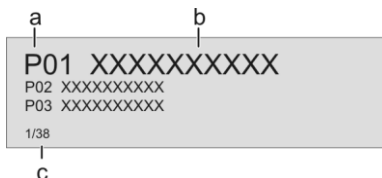

Calling up the Favourites list

- The first step is to switch to one of the sources listed above.
- Press the **(☰/III)**-button on the remote control or the **(☰)**-button on the front panel to call up the Favourites list.











- a) Here the program location number is displayed within the list. Since it is possible to erase individual list items, the numbering may not be continuous.
- b) The selected list entry is displayed in enlarged form.
- c) Position display in the Favourites list.

Erasing a favourite from the Favourites list

Open the Favourites list by pressing the  button. Use the  /  buttons to select the station in the list which you wish to erase, then hold the red  button pressed in; this action removes the item from the Favourites list.







 Erasing a Favourite does not cause the following Favourites to move up the list. The station position is no longer displayed after erasure, but a new Favourite can still be assigned to it.

Selecting a favourite from the list





- Press the  / -button to call up the Favourites list.
- Use the  /  buttons to select a stored item from the Favourites list. The selected favourite is displayed in enlarged form.
- Select the favourite to be played by pressing the  or the  / -button.
- You can return to the station to which you are currently listening (quit) by pressing the  button.

Sorting Favourites lists

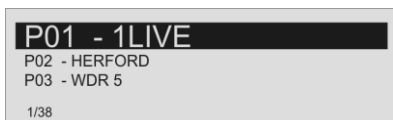
The sequence of items in the Favourites list you have created can be altered in any way you wish. This is the procedure for changing the order of the list:

- The first step is to call up the Favourites list by briefly pressing the  / -button.
- Use the  /  buttons to select the favourite whose position you wish to change. The selected Favourite is displayed in enlarged form.
- Pressing the  / -button activates the Sort function for the selected favourite. The favourite is highlighted on the screen.



- Now move the activated favourite to your preferred position in the Favourites list.
- A further press on the  / -button de-activates the Sort function, and the favourite is stored at the new position.
- Briefly press the  / - button again to close the Favourites list.

 If you have previously erased a number of favourites, you may well find that some program locations in the Favourites list are missing (empty). Nevertheless, the favourites can still be moved to any location in the list!



Operating the radio

The **MP 8** features an **FM tuner** (VHF radio) with HD Radio™ technology*, a **DAB / DAB+** receiving section (digital radio) and also includes the facility to stream **Internet radio**. The following section describes in detail how to operate the individual radio sources. HD Radio technology enables radio stations to transmit analogue and digital programmes on the same frequency simultaneously.

* HD Radio™ technology only available in US-version.

FM - Radio

Selecting FM radio

Briefly press the  button on the **FM8** remote control handset, or the  button on the **MP 8** - repeatedly if necessary - until the source "**FM Radio**" is displayed on the screen.

General

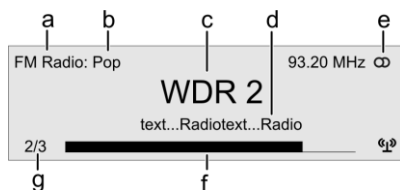

- Displays the type of reception currently in use.
 - Hear the music type or style is displayed, e.g. Pop Music.
 - This information is only displayed if the transmitting station broadcasts it as part of the *RDS* system. If you are listening to a station which does not support the *RDS* system, or only supports it in part, these information fields remain empty.
 - The frequency and / or the station name is displayed in enlarged form. If a station name is displayed, its frequency is shown in area 'e'.
 - These lines display information which is broadcast by the station (e.g. Radio text).
 - Display of Stereo 'Ⓢ' / Mono "●"
- The *field strength*  and therefore the reception quality to be expected from the set transmitting station can be assessed from the field strength.
- FM Radio: when receiving a HD Radio broadcast, the screen displays the currently selected programme from the total number of programmes available, e.g. programme 2 of total 3 available.

Automatic station search

A brief press on the **SRC**-button on the machines front panel or a long press on the **FM**-button on the **FM8** remote control calls up the Station list menu. The following select points are available:

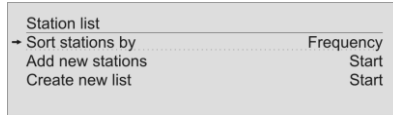

- If you wish to create a new station list, select the item **“Create new list”** and confirm your choice with **▶OK** / **OK**.
- The station search begins, and automatically searches for all radio stations which the machine is able to pick up.
- If you wish to update an existing list, select the item **“Add new stations”**.
- The menu item **“Sort stations by ...”** allows you to sort the stored list by any of several criteria.

Selecting a station from the Station list

Pressing the **◀**-button opens the list of all stored stations.

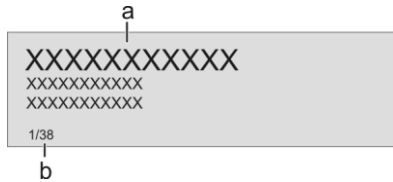

- Use the **▲** / **▼** buttons to select one of the stored stations. The station you choose is now displayed in enlarged form. Press the **▶** or **▶OK** / **OK**-button to select the enlarged station for playing. Pressing the **◀** button returns you to the station list.
- Position indicator in the Favourites list.

i Stations to which you often listen can be stored in a Favourites list; this makes it easier to select them (see the section entitled **“Favourites list”**).

Selecting an HD Radio station

The method of selecting an HD Radio station is the same as for an analogue FM station. As soon as you select a station with an HD Radio programme, playback automatically switches to the digital programme. As soon as the **CALA CDR** is playing an HD Radio broadcast, the display of reception mode in area **“a”** (see illustration: FM Radio display) switches to **“HD Radio”**, while screen area **“g”** shows the number of available stations, e.g. **“1/4”** (First HD Radio programme selected from 4 available).

You can switch between the available HD Radio programmes using the **◀◀** / **▶▶** buttons.

i Please note that the HD Radio programs can be called up only, if they are stored in the station list. Please refer **“Automatic station search”** and **“Selecting a station from the list”** above.

RDS functions

- i** If the station being received is broadcasting relevant RDS data, the following information will be displayed on the screen:
- **Station name**
 - **Radio text**
 - **Program type (genre)**
 - **Program Service Data (PSD)***
- For stations that do not support the RDS system or only partially or with weak reception, no information will be displayed.

* Only possible when receiving HD Radio transmissions.

Switching Radio Text on and off

The Radio text function can be switched on and off by briefly pressing the -button on the remote control handset.

- i** By pressing the -button several times, the different display modes are switched. With or without Radiotext.

HD Radio stations are also capable of transmitting what is known as PSD information (e.g. track and artist) in addition to Radiotext. As soon as an HD Radio station is picked up, you can cycle through the following operational states by repeatedly pressing the -button: Radiotext on → PSD information → Radiotext off. If the radio station is not transmitting Radiotext or PSD information, the display remains blank.

Mono / Stereo (only FM – Radio)

You can toggle the radio of the **MP 8** between stereo and mono reception by a long press on the -button. The reception mode is shown on the screen by the following symbols:



• **'●'** (Mono) or **'⊕'** (Stereo)

If the station you wish to listen to is very weak or very distant, and can only be picked up with severe background noise, you should always switch to MONO mode as this reduces the unwanted hiss significantly.

- i** The Mono and Stereo symbols are only shown in the detailed screen display.

DAB - Radio

Selecting DAB radio

Briefly press the -button on the **FM8** remote control handset, or the -button on the **MP 8** - repeatedly if necessary - until the source "**DAB Radio**" is displayed on the screen.

- i** Depending on the frequency band (block), it may take up to two seconds to switch stations when in **DAB mode**.

Display

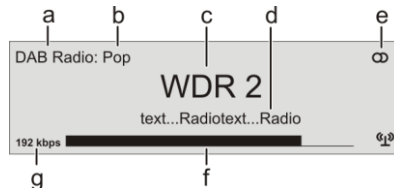

- a) Displays the type of reception currently in use.
Hear the music type or style is displayed, e.g. Pop Music.
This information is only displayed if the transmitting station broadcasts it as part of the *RDS* system. If you are listening to a station which does not support the *RDS* system, or only supports it in part, these information fields remain empty.
- b) The frequency and / or the station name is displayed in enlarged form. If a station name is displayed, its frequency is shown in area 'e'.
- c) These lines display information which is broadcast by the station (e.g. Radio text).
- d) Display of Stereo 'Ⓜ'.
- e) The *field strength* (P) and therefore the reception quality to be expected from the set transmitting station can be assessed from the field strength.
- f) Bit-rate of the broadcasting station when listening to DAB radio.
- * The higher the bit-rate, the better the station's sound quality.

Automatic station search

A brief press on the **SRC**-button on the machines front panel or a long press on the **FM8** -button on the **FM8** remote control calls up the Station list menu. The following select points are available:

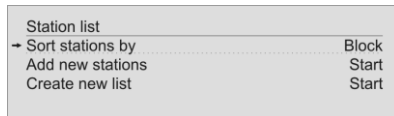





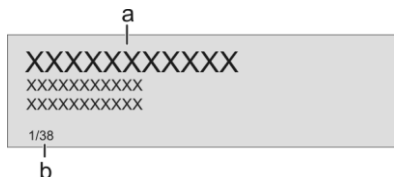

- If you wish to create a new station list, select the item “**Create new list**” and confirm your choice with **▶OK** / **OK**.
- The station search begins, and automatically searches for all radio stations which the machine is able to pick up.
- If you wish to update an existing list, select the item “**Add new stations**”.
- The menu item “**Sort stations by ...**” allows you to sort the stored list by any of several criteria.

Selecting a station from the Station list

Pressing the **◀**-button opens the list of all stored stations.



- a) Use the **▲** / **▼** buttons to select one of the stored stations. The station you choose is now displayed in enlarged form. Press the **▶** or **▶OK** / **OK**-button to select the enlarged station for playing.
Pressing the **◀** button returns you to the station list.

- b) Position indicator in the Favourites list.
- c) Use the  /  buttons to select one of the stored stations. The station you choose is now displayed in enlarged form. Press the  or  / -button to select the enlarged station for playing. Pressing the  button returns you to the station list.
- d) Position indicator in the Favourites list.

 Stations to which you often listen can be stored in a Favourites list; this makes it easier to select them (see the section entitled “**Favourites list**”).

RDS functions



If the station being received is broadcasting relevant RDS data, the following information will be displayed on the screen:

- **Station name**
- **Radio text**
- **Program type (genre)**

For stations that do not support the RDS system or only partially or with weak reception, no information will be displayed.

Internet-Radio and podcasts

Selecting Internet Radio as source

Briefly press the -button on the **FM8** remote control handset, or the -button on the **MP 8** - repeatedly if necessary - until the source “**Internet Radio**” is displayed on the screen.

Selecting podcasts





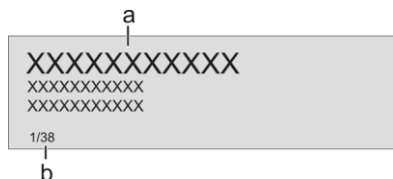

Select the “**Podcasts**” entry instead of the “**Internet Radio**” entry. The source “**Podcasts**” is operated in the same way as the “**Internet Radio**” source.

 The method of operating music services is described separately in the section entitled “**Operating music services**”.



Playback

The music content to be played is selected with the help of Select lists. These lists are controlled using the navigation buttons (cursor buttons) on the remote control handset.





- a) Use the  / -buttons to select the desired entry from the list.
A brief press selects the previous / next entry within the list. The scrolling speed can be increased by holding the button pressed.
The list entry you choose is now displayed in enlarged form.
Press the  or  / -button to open or start the list entry shown in enlarged form.
Pressing the  button returns you to the list.
- b) Indicates the currently selected point within the opened list.

Starting playback

Press the -button on the remote control handset or the  button on the machine's front panel to start playback.

Stopping playback

A long press on the  button of the **FM8** or a brief press on the  button on the **MP 8's** front panel halts playback.











Favourites lists

Stations to which you often listen can be stored in a Favourites list; this makes it easier to select them (see the section entitled "**Favourites list**").

Search function

The Search function provides a means of locating Internet radio stations swiftly.

This is the procedure for searching for a particular Internet radio station:

- Locate the Select list for the entry "**Radio**", then use the  /  buttons to select the "**Search**" item, and confirm your choice by pressing the  / -button.
- You will now see a window in which you can enter the keyword using the  /  buttons on the remote control handset: repeatedly press the appropriate button until the desired letter appears on the screen. Briefly press the  button to enter the next letter.
- Press the  button to erase any letter.
- Briefly press the  / -button to start the search.
- After a short delay you will see a list of the search results.



The search strings can consist of up to eight characters. It is also possible to enter multiple keywords separated by a space character, e.g. "BBC Rad".

Operating music services



General information

The *Cala* supports playback of music services such as TIDAL. To make use of music services you may need to take out a paid subscription with the appropriate provider.

Use of music services requires the input of access data (username and password). These access data can be stored separately for each provider in the "Music services" menu within the System Configuration menu (see the section entitled "**Basic settings of the MP 8**").

 Future music services and others which are not currently supported may be added subsequently by updates to the firmware of the **MP 8**.



Selecting the music service

Briefly press the -button on the **FM8** remote control handset, or the -button on the **MP 8** - repeatedly if necessary - until the desired music service is displayed on the screen.

Playback

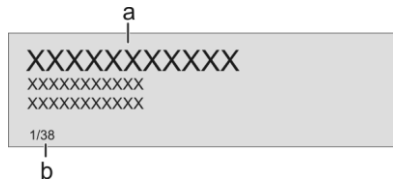
The music content to be played is selected with the help of Select lists. These lists are controlled using the navigation buttons (cursor buttons) on the remote control handset.



a) Use the  /  buttons to select the desired entry from the list.

A brief press selects the previous / next entry within the list. The scrolling speed can be increased by holding the button pressed.



The list entry you choose is now displayed in enlarged form.

Press the  or  /  button to open or start the list entry shown in enlarged form.



Pressing the  button returns to the list.

b) Indicates the currently selected point within the opened list.



Starting playback

Press the -button on the remote control handset or the  button on the machine's front panel to start playback.

Stopping playback







A long press on the  button of the **FM8** or a brief press on the  button on the **MP 8's** front panel halts playback.



Skipping tracks

A brief press on the  /  buttons during playback causes the device to jump to the next or previous piece of music within the current playlist.

 The exact form of the displayed list and the preparation of the content depend to a large extent on the music service provider. You may therefore find that in some cases not all the functions described in these instructions can be used.

Search function

To help you find your way swiftly to the item you seek from the vast range of offerings, it is possible to search the content of the music service provider in a targeted fashion. This is accomplished by first opening the Select list of the music service in question. Navigate your way to the **"Search"** entry, and confirm your choice with the  / -button; the screen displays the message **"Search"**. While this display is shown enter a letter using the  /  buttons on the remote control handset: repeatedly press the appropriate button until the desired letter appears on the screen. Briefly press the  button to enter the next letter. To erase a letter, press the  button.

When you have entered the data, briefly press the  / -button to start the search.

After a short pause you will see a list containing the search results.

The list of results will vary according to the service you are using. Many services allow you to filter the search results according to artiste, album or track once the initial search is complete.

 The search strings can consist of up to eight characters. It is also possible to enter multiple keywords separated by a space character, e.g. "The Beat".

Playlists and favourites

Most music services offer the facility to register on the provider's website with the user data, create dedicated playlists, and manage the lists conveniently.

Once created, the playlists appear in the Select list of the corresponding music service, where they can be called up and played via the **MP 8**

The location within the select list at which the playlists can be accessed varies from one music service to another. Often these folders are named "My music", "Library", "Favourites" or similar.

Operating the UPnP source



(Streaming Client)

General information on the streaming client

The **MP 8** features what is known as a 'streaming client'. This facility makes it possible to play music files stored on PCs or servers (NAS) within the network.

The media content formats which the **MP 8** can reproduce are very wide-ranging, and extend from compressed formats such as MP3, AAC and OGG Vorbis to high-quality non-compressed data formats such as FLAC, ALAC, AIFF and WAV, which are thoroughly audiophile in nature. Since virtually no read or data errors occur when electronic memory media are accessed, the potential reproduction quality is even higher than that of CD. The quality level may even exceed that of SACD and DVD-Audio.





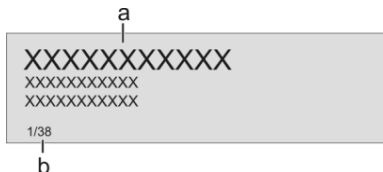

Selecting the UPnP source

Briefly press the -button on the **FM8** remote control handset, or the -button on the **MP 8** - repeatedly if necessary - until the source "UPnP / DLNA" is displayed on the screen.

Playback

The music content to be played is selected with the help of Select lists. These lists are controlled using the navigation buttons (cursor buttons) on the remote control handset.





- a) Use the  /  buttons to select the desired entry **Server / Folder / Track** from the list.
A brief press selects the previous / next entry within the list. The scrolling speed can be increased by holding the button pressed.
The list entry you choose is now displayed in enlarged form.
Press the  or  / - button to open or start the list entry shown in enlarged form.
Pressing the  button returns you to the list.
- b) Indicates the currently selected point within the opened list.





The exact form of the displayed list and the preparation of the content also depend to a large extent on the capabilities of the server, i.e. the full facilities of the **MP 8** cannot be exploited with all servers or media. You may therefore find that in many cases not all the functions described in these instructions can be used.



Starting playback

Press the -button on the remote control handset or the  button on the machine's front panel to start playback.



Stopping playback

A long press on the  button of the **FM8** or a brief press on the  button on the **MP 8's** front panel halts playback.

Skipping tracks

A brief press on the  /  buttons during playback causes the device to jump to the next or previous piece of music within the current playlist.

Playback of directories

In addition to the facility to play back individual folder content, it is also possible to play back entire directories. This is accomplished by selecting the folder of the directory to be played, then pressing the  / -button to start playback. Playback commences with the first entry in the list of content to be played. If an entry in the list should contain a folder with additional sub-folders, the content of the lowest folder is always played first. This is followed by the content of the next higher folder level, etc. (see diagram right).

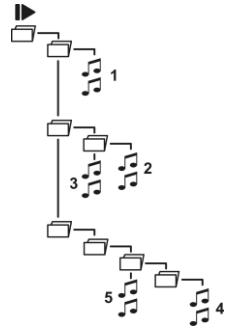

Playback with roon

General information

The **MP 8** supports playback via Roon.

Roon is a fee required software solution that manages and organizes your music stored on a server. Furthermore the streaming service TIDAL can be integrated.

Playback

The operation is exclusively done via the Roon-App. The **MP 8** is recognized as a playback device (client) and can be selected for playback in the app. As soon as Roon is used for playback, "Roon" appears on the **MP 8** display as source.



Further information about Roon and its operation can be found at: <https://roonlabs.com>



Playing USB memory media

(USB Media source)

General information

The **MP 8** is capable of playing music files stored on USB memory media, and features two USB sockets for this purpose: **USB IN** on the front panel and **USB HDD** on the back panel.



The memory medium can be formatted with any of the following file systems:

FAT16, FAT32, NTFS, ext2, ext3 or ext4.

It is also possible to power the USB memory medium via the USB socket, provided that the unit's current drain accords with the USB norm. Normed 2.5 inch USB hard discs can be connected to the socket directly, without requiring their own mains PSU.

Selecting USB Media as source

Briefly press the -button on the **FM8** remote control handset, or the -button on the **MP 8** - repeatedly if necessary - until the source "**USB Media**" is displayed on the screen.

All USB memory media connected to the machine is now displayed. If no USB memory medium is found, the screen displays the message "**No devices found**".

Playback

The music content to be played is selected with the help of Select lists. These lists are controlled using the navigation buttons (cursor buttons) on the remote control handset.

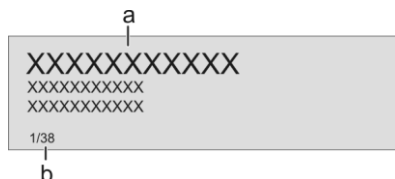

- a) Use the / buttons to select an (a) **USB memory / folder / track** from the list.

A brief press selects the previous / next entry within the list. The scrolling speed can be increased by holding the button pressed.



The list entry you choose is now displayed in enlarged form.

Press the or / -button to open or start the list entry shown in enlarged form.



Pressing the button returns you to the list.

- b) Indicates the currently selected point within the opened list.



Starting playback

Press the -button on the remote control handset or the  button on the machine's front panel to start playback.



Stopping playback

A long press on the  button of the **FM8** or a brief press on the  button on the **MP 8's** front panel halts playback.

Skipping tracks

A brief press on the  /  buttons during playback causes the device to jump to the next or previous piece of music within the current playlist.

Playback of directories

In addition to the facility to play back individual folder content, it is also possible to play back entire directories. This is accomplished by selecting the folder of the directory to be played, then pressing the  / -button to start playback. Playback commences with the first entry in the list of content to be played. If an entry in the list should contain a folder with additional sub-folders, the content of the lowest folder is always played first. This is followed by the content of the next higher folder level, etc. (see diagram right).

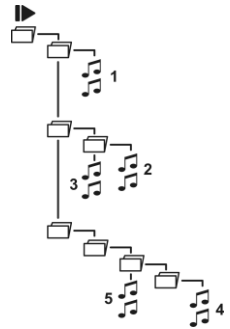



Operating the Bluetooth source

The **MP 8**'s integral Bluetooth interface provides a means of transferring music wirelessly from devices such as smart-phones, tablet PCs, iPods, etc. to the **MP 8**

-  For a successful audio Bluetooth transfer from a mobile device to the **MP 8** the mobile device must support the A2DP Bluetooth audio transfer protocol.

Selecting Bluetooth

Briefly press the  button on the **FM8** remote control handset, or the  button on the **MP 8** - repeatedly if necessary - until the source "**Bluetooth**" is displayed on the screen.

Setting up audio transfer

Before music from a Bluetooth-capable device can be played through the **MP 8**, the external device must first be registered to the **MP 8**. As long as the **MP 8** is switched on and no device is connected, it is always ready to receive. In this state the screen displays the message 'not connected'.

This is the procedure for establishing a connection:

- Start a search for Bluetooth equipment on your mobile device.
- When it finds the **MP 8**, make the connection to your mobile device.

Once the connection is successfully established, the message on the **MP 8**'s screen switches to "connected to *YOUR DEVICE*".

-  If your device requests a PIN code, this is always "0000".

-  Due to the large number of different equipment on the market, we are only able to provide a general description for setting up the radio connection. For detailed information please refer to the operating instructions supplied with your device.



Playback functions

Information on the piece of music being played is displayed on the integral screen of the connected mobile device. If possible we recommend that you leave the screen backlight switched on permanently to ensure that it is clearly legible.



Some Bluetooth devices which support the AVRCP protocol can be controlled by **MP 8**'s **FM8** remote control handset.

The behaviour and method of operating the connected mobile device are determined by the device itself. In general terms the function of the buttons the **FM8** remote control handset are as follows:



Starting playback

Press the -button on the remote control handset or the  button on the machine's front panel to start playback.

Stopping playback

A long press on the  button of the **FM8** or a brief press on the  button on the **MP 8**'s front panel halts playback.

Skipping tracks

A brief press on the  /  buttons during playback causes the device to jump to the next or previous piece of music within the current playlist.

-  Please note that many AVRCP-capable mobile devices do not support the controlling through the **MP 8**. In case of doubt, please ask the manufacturer of your mobile device.

Notes

-  The **MP 8** has been tested with a large number of Bluetooth-capable mobile devices. However, we are unable to guarantee general compatibility with all devices available commercially since the range of equipment is so wide, and the various implementations of the Bluetooth standard differ widely in some cases. If you encounter a problem with Bluetooth transfer, please contact the manufacturer of the mobile device.



The maximum range of a Bluetooth audio transfer is normally about 3 to 5 metres, but the effective range may be affected by a number of factors. To achieve good range and interference-free reception there should be no obstacles or persons between the **MP 8** and the mobile device.

Bluetooth audio transfers take place in what is known as the “everyman frequency band”, in which many different radio transmitters operate - including WLAN, garage door openers, baby intercoms, weather stations, etc. Radio interference caused by these other services may cause brief dropouts or - in rare cases - even failure of the connection, and such problems cannot be excluded. If problems of this kind occur frequently in your environment, we recommend that you use the Streaming Client or the USB input of the **MP 8** instead of Bluetooth.



By their nature, Bluetooth transmissions always involve data reduction, and the attainable sound quality varies according to the mobile device in use, and the format of the music to be played. As a basic rule the maximum quality of music which is already stored in a data-reduced format, such as MP3, AAC, WMA or OGG-Vorbis, is worse than with uncompressed formats such as WAV or FLAC. For the highest reproduction quality we always recommend the use of the Streaming Client or the USB input of the **MP 8** instead of Bluetooth.

Operating the Disc player



Selecting CD as source

Briefly press the  button on the **FM8** remote control handset, or the  button on the **MP 8** - repeatedly if necessary - until the source "**Disc**" is displayed on the screen.

Inserting a CD



- Open the CD drawer by pressing the  button on the **FM8** or by pressing the  button on the machine's front panel.
- Place the disc **centrally** in the appropriate depression in the drawer, **with the side to be played facing down**.



- Close the CD drawer by pressing the  button on the **FM8** again or by pressing the  button on the front panel.
- When you close the drawer, the machine immediately reads the CD's 'Table of Contents'; the screen displays the message '**Reading**'. During this period all button-presses are ignored.
- The screen then displays the total number of tracks on the CD in the drawer, e.g.: '**13 Tracks 60:27**'.

It is also shows the current mode of operation, e.g. 



Playing a CD

Press the  button to begin the playback process. Playback starts, and the screen shows the mode of operation () and the number of the track currently being played: "Track 1".

The CD stops after the final track, and the screen again displays the total number of CD tracks and the overall running time.



Variations

If you press the  /  button after placing the CD in the machine, the drawer closes and playback starts with the first track. The open drawer also closes if you enter the number of a track using the remote control handset.



You can interrupt playback at any time by pressing the  button. During the interruption the screen displays the  symbol. Press the  button again to resume playback.

Briefly pressing the  or  button during playback causes the player to skip to the start of the preceding / next track.

A long press on the  button of the **FM8** concludes playback.

A further long press on the  button on the remote control or a brief press on the  button on the front panel opens the CD drawer.

Track Select During playback

Briefly press the  or  button repeatedly until the number of the track you want to hear appears on the integral screen.

Releasing the button interrupts playback briefly, and after this the desired track is played.

CD Text

If the disc in the drawer contains CD text, this can be superimposed or suppressed by briefly pressing the  button repeatedly if necessary.

Playback mode

The CD player in the **MP 8** features various playback modes. During playback the current playback mode is shown on the screen.

Repeat

A long press on the  button, repeatedly if necessary, causes the machine to cycle through different playback modes.

Screen symbols



The tracks of the CD or a *playback program* are continuously repeated in the **preset sequence**.



The track of the CD or a *playback program* which has just been played is continuously repeated.

No symbol







Normal playback of the whole disc, or normal program playback.

Playback Program

Creating a playback program



A playback program consists of up to thirty tracks of a CD stored in any order you like. This can be useful, for example, when you are preparing a cassette recording. A playback program can only be created for the CD currently in the disc drawer of the **MP 8**. The program remains stored until it is erased again, or until the CD drawer is opened.

When you place the CD in the drawer, the screen displays the total number of tracks on the disc, e.g.: **'13 Tracks 60:27'**. For creating a playback program the disc must be stopped.



- Press the  button to activate playback programming mode.
- The screen displays the message **'Add Track 1 to Program'** and **'0 Tracks / 0:00 Program time'**.
- Repeatedly press the  or  button briefly until the number of the desired track appears on the screen after **'Track'**.
- Now store the track in the playback program by briefly pressing the  button.
- The screen shows the number of tracks and the total playing time of the play-back program. Select all the remaining tracks of the program in the same manner, and store them by briefly pressing the  button.
- If you store thirty tracks, the screen displays the message **'Program full'**. The playback programming process is concluded when all the desired tracks have been stored.
- End the playback programming process.
- Hold the  button pressed in for about one second

Playing a playback program

The playback program can now be played.

- Start the playback process by a brief press on the  button
Playback starts with the first track of the playback program. The screen displays the message **"Prog"** while a playback program is playing. The  and  buttons select the previous or next track, but only within the playback program.

Erasing a playback program

- Briefly pressing  button in STOP mode opens the CD drawer, and thereby erases the playback program.
- A playback program can also be erased without opening the CD drawer:
- Erase the playback program.
- Hold the  button pressed in again for about one second
- The playback program is now erased.

Installation, Using the system for the first time, Safety notes

This section describes all those matters which are of fundamental importance when setting up and first using the equipment. This information is not relevant in daily use, but you should nevertheless read and note it before using the equipment for the first time.

Back panel connections

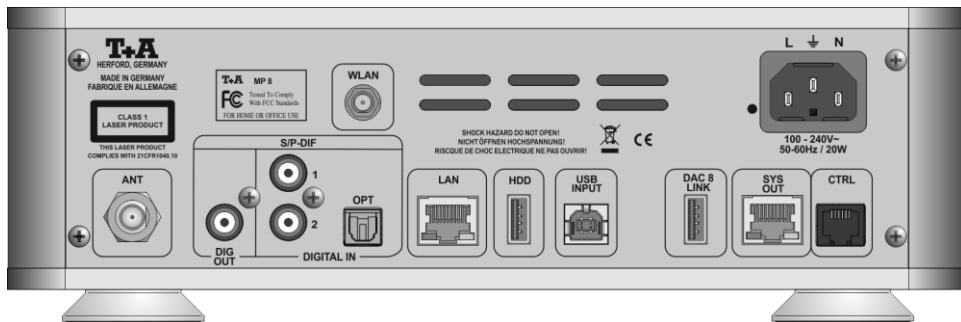

ANT (Antenna input)

This FM antenna input can be connected to a normal 75 Ω FM home antenna or to TV/FM cable networks. For first-class reception quality a high-performance aerial system, competently installed, is a basic requirement.

DIG OUT

The signals from the selected source are available at this socket. The data can be fed to another device such as a surround decoder or a DAC.

I It is not always possible to make a recording of all media, as some copyright holders employ copy protection measures to prevent this.

DIGITAL IN 1 DIGITAL IN 2

Inputs for digital source devices with coaxial (RCA) outputs.

At this input the **MP 8** accepts digital stereo signals (S/P-DIF signals) with sampling rates from 32kHz up to 192 kHz.

DIGITAL IN OPT

Inputs for digital source devices with optical (TOSLINK) outputs.







At this input the **MP 8** accepts digital stereo signals (S/P-DIF signals) with sampling rates from 32kHz up to 96 kHz.

HDD

Socket for a USB memory stick or external hard discs

The storage medium can be formatted with the FAT16, FAT32, NTFS, ext2, ext3 or ext4 file system.

The USB storage medium can be powered directly via the USB port provided that its current drain is in accordance with the USB norm. Normalised 2.5" USB hard discs can be connected directly, i.e. without a separate mains PSU.

USB INPUT	<p>The MAC or Windows computer connected to the DAC 8 DSD can be connected here. For details please see the wiring diagram for the device in 'Appendix A'.</p> <p> If the MP 8 is operated in conjunction with a DAC 8 DSD, the USB input of the DAC 8 DSD is used to connect the MP 8. In this case the USB INPUT on the MP 8 is used to connect the MAC or Windows computer. When the USB input on the DAC 8 DSD is selected, the signals from the connected computer are passed through to the DAC 8 DSD.</p> <p> When the device is used without the DAC 8 DSD this socket has no function.</p>
DAC 8 LINK	<p>Audio connection to the DAC 8 DSD. Connect the DAC 8 LINK socket to the USB input of the DAC 8 DSD. For details please see the wiring diagram for the device in 'Appendix A'.</p>
SYS OUT	<p>Control interface for use with a DAC 8 DSD.</p> <p> If the MP 8 is operated in combination with a DAC 8 DSD, this socket must be connected to the SYS IN socket on the DAC 8 DSD. For details please see the wiring diagram for the device in 'Appendix A'.</p>
CTRL (Control)	<p>This interface can also be used for control of the DAC 8 DSD – for example in combination with a CRESTRON or AMX home automation system.</p>
LAN	<p>Socket for connection to a wired LAN (Ethernet) home network.</p> <p> If a LAN cable is connected this will have priority over wireless WLAN networks. The WLAN module of the MP 8 will automatically be disabled.</p>
WLAN	<p>Input socket for WLAN antenna</p> <p> Automatic activation of the WLAN module After powering on the MP 8 detects if it is connected to a wired LAN Network. If no wired LAN connection is found, the MP 8 will automatically activate its WLAN module and it will try to get access to your WLAN network.</p> <p> Attention! When WLAN shall be used, the LAN socket must be left unconnected.</p>
Mains input	<p>The mains lead is plugged into this socket. For information on correct mains connections please refer to the notes in the Chapters 'Using the system for the first time', 'Wiring' and 'Safety Notes'.</p>

Installation and wiring

Carefully unpack the unit and store the original packing material carefully. The carton and packing are specially designed for this unit and will be needed again if you wish to move the equipment at any time.

If you have to transport the device, it must always be carried or sent in its original packaging in order to prevent damage and defects.

If the unit gets very cold (e. g. when being transported), condensation may form inside it. Please do not switch it on until it has had plenty of time to warm up to room temperature, so that any condensation evaporates completely.

If the device has been in storage, or has not been used for a protracted period (> two years), it is essential to have it checked by a specialist technician before re-use.

Before placing the unit on sensitive laquer or wood surfaces please check the compatibility of the surface and the unit's feet on a non visible point and if necessary use an underlay. We recommend a surface of stone, glass, metal or the like.

The unit should be placed on a rigid, level base (See also chapter "**Safety notes**"). When placing the unit on resonance absorbers or anti-resonant components make sure that the stability of the unit is not reduced.

The unit should be set up in a well ventilated dry site, out of direct sunlight and away from radiators.

The unit must not be located close to heat-producing objects or devices, or anything which is heat-sensitive or highly flammable.

Mains and loudspeaker cables, and also remote control leads must be kept as far away as possible from signal leads and antenna cables. Never run them over or under the unit.

ⓘ Notes on connections:

A complete connection diagram is shown in '**Appendix A**'.

- Be sure to push all plugs firmly into their sockets. Loose connections can cause hum and other unwanted noises.
- The device is intended to be connected to mains outlet with protective earth connector. Please connect it only with the mains cable supplied to a properly installed mains outlet with protective earth connector.
- To achieve maximum possible interference rejection the mains plug should be connected to the mains socket in such a way that phase is connected to the mains socket contact marked with a dot (●). The phase of the mains socket can be determined using a special meter. If you are not sure about this, please ask your specialist dealer.

If you encounter problems when setting up and using the amplifier for the first time please remember that the cause is often simple, and equally simple to eliminate. Please refer to the section of these instructions entitled '**Trouble shooting**'.

Loudspeaker and signal cables

Loudspeaker cables and signal cables (inter-connects) have a significant influence on the overall reproduction quality of your sound system, and their importance should not be under-estimated. For this reason **T+A** recommends the use of high-quality cables and connectors.

Our accessory range includes a series of excellent cables and connectors whose properties are carefully matched to our speakers and electronic units, and which harmonise outstandingly well with them.

For difficult and cramped situations the **T+A** range also includes special-length cables and special-purpose connectors (e. g. right-angled versions) which can be used to solve almost any problem concerning connections and system location.

Changing the batteries

The **FM8** is fitted with an internal rechargeable battery (Li-Ion battery), which cannot be removed or replaced by the user. If you eventually notice that the battery only retains a little of its original capacity, and the period you can use the **FM8** is greatly reduced, then it is time to contact your **T+A** dealer and ask him to fit a replacement battery.



Caution!

Batteries should not be exposed to excessive heat like sunshine, fire or the like.

If the battery is replaced improperly, there is danger of explosion.

Always replace batteries by batteries of the same or an equivalent type.



Disposing of exhausted batteries:

Exhausted batteries must never be thrown into the household waste! They should be returned to the battery vendor (specialist dealer) or your local toxic waste collection point, so that they can be recycled or disposed in a proper way. Most local authorities provide collection centres for such waste, and some provide pick-up vehicles for old batteries.

Care of the unit

Disconnect the mains plug at the wall socket before cleaning the case. The surfaces of the case should be wiped clean with a soft, dry cloth only.

Never use solvent-based or abrasive cleaners!

Before switching the unit on again, check that there are no short-circuits at the connections, and that all cables are plugged in correctly.

Storing the unit

If the device has to be stored, place it in its original packaging and store it in a dry, frost-free location. Storage temperature range 0...40 °C

Safety notes

For your own safety please consider it essential to read these operating instructions right through, and observe in particular the notes regarding setting up, operation and safety.

Installation

Please consider the weight of the device. Never place the device on an unstable surface; the machine could fall off, causing serious or even fatal injury. Many injuries, especially to children, can be avoided if the following simple safety precautions are observed:

- Use only such items of furniture which can safely bear the weight of the device.
- Ensure that the device does not project beyond the edges of the supporting furniture.
- Do not place the device on tall furniture (e.g. bookshelves) without securely anchoring both items, i.e. furniture and device.
- Explain to children the hazards involved in climbing on furniture to reach the device or its controls.

When installing the unit on a shelf or in a cupboard it is essential to provide an adequate flow of cooling air, to ensure that the heat produced by the unit is dissipated effectively. Any heat build-up will shorten the life of the unit and could be a source of danger. Be sure to leave free space of 10 cm around the unit for ventilation.

If the system components are to be stacked then the amplifier must be the top unit. Do not place any object on the top cover.

The unit must be set up in such a way that none of the connections can be touched directly (especially by children). Be sure to observe the notes and information in the section '**Installation and Wiring**'.

Power supply

The device is intended to be connected to mains outlet with protective earth connector. Please connect it only with the mains cable supplied to a properly installed mains outlet with protective earth connector.

The power supply required for this unit is printed on the mains supply socket. The unit must never be connected to a power supply which does not meet these specifications. If the unit is not to be used for a long period disconnect it from the mains supply at the wall socket.

Mains leads / Mains plug

Mains leads must be deployed in such a way that there is no danger of damage to them (e. g. through persons treading on them or from furniture). Take particular care with plugs, distribution panels and connections at the device.

Unplugging the mains plug will disconnect the device from the mains for service and repair. Please make sure that the mains plug is easily accessible.

Enclosure openings

Liquid or particles must never be allowed to get inside the unit through the ventilation slots. Mains voltage is present inside the unit, and any electric shock could cause serious injury or death. Never exert undue force on mains connectors.

Protect the unit from drips and splashes of water; never place flower vases or fluid containers on the unit.

Do not place naked flame sources, such as candle lights on the device.

Supervision of device operation

Like any other electrical appliance this device should never be used without proper supervision. Take care to keep the unit out of the reach of small children.

Service, Damage

The case should only be opened by a qualified specialist technician. Repairs and fuse replacements should be entrusted to an authorised **T+A** specialist workshop. With the exception of the connections and measures described in these instructions, no work of any kind may be carried out on the device by unqualified persons.

If the unit is damaged, or if you suspect that it is not functioning correctly, immediately disconnect the mains plug at the wall socket, and ask an authorised **T+A** specialist workshop to check it.

Approved usage



The device is designed to operate in a temperate climate and altitudes up to 2000 m above sea level. The range of permissible operating temperatures is +10 ... +35°C.

This device is designed exclusively for reproducing sound and/or pictures in the domestic environment. It is to be used in a dry indoor room which meets all the recommendations stated in these instructions.

Where the equipment is to be used for other purposes, especially in the medical field or any field in which safety is an issue, it is essential to establish the unit's suitability for this purpose with the manufacturer, and to obtain prior written approval for this usage.

Over voltage

The unit may be damaged by excess voltage in the power supply, the mains circuit or in aerial systems, as may occur during thunderstorms (lightning strikes) or due to static discharges.

Special power supply units and excess voltage protectors such as the **T+A 'Power Bar'** mains distribution panel offer some degree of protection from damage to equipment due to the hazards described above.

However, if you require absolute security from damage due to excess voltage, the only solution is to disconnect the unit from the mains power supply and any aerial systems.

To avoid the risk of damage by overvoltages we recommend to disconnect all cables from this device and your HiFi system during thunderstorms.

All mains power supply and aerial systems to which the unit is connected must meet all applicable safety regulations and must be installed by an approved electrical installer.

Approval and conformity with EC directives

In its original condition the unit meets all currently valid European regulations. It is approved for use as stipulated within the EC. By attaching the CE symbol to the unit **T+A** declares its conformity to the EC directives and the national laws based on those directives. The declaration of conformity can be downloaded from www.ta-hifi.com/DoC.

The original, unaltered factory serial number must be present on the outside of the unit and must be clearly legible! The serial number is a constituent part of our conformity declaration and therefore of the approval for operation of the device. The serial numbers on the unit and in the original **T+A** documentation supplied with it (in particular the inspection and guarantee certificates), must not be removed or modified, and must correspond.

Infringing any of these conditions invalidates **T+A** conformity and approval, and the unit may not be operated within the EC. Improper use of the equipment makes the user liable to penalty under current EC and national laws.

Any modifications or repairs to the unit, or any other intervention by a workshop or other third party not authorised by **T+A**, invalidates the approval and operational permit for the equipment.

Only genuine **T+A** accessories may be connected to the unit, or such auxiliary devices which are themselves approved and fulfil all currently valid legal requirements.

When used in conjunction with auxiliary devices or as part of a system this unit may only be used for the purposes stated in the section '**Approved usage**'.

Disposing of this product



The only permissible method of disposing of this product is to take it to your local collection centre for electrical waste.

The **FM8** contains a Li-Ion battery. Like any other electrical device, the **FM8** must not be discarded in the normal domestic waste. It must be taken to your local collection point for electrical scrap.

FCC Information to the user



(for use in the United States of America only)

Class B digital device – instructions:

Note: This equipment has been tested and found to comply with the limits for a Class B digital device, pursuant to Part 15 of the FCC Rules. These limits are designed to provide reasonable protection against harmful interference in a residential installation. This equipment generates, uses and can radiate radio frequency energy and, if not installed and used in accordance with the instructions, may cause harmful interference to radio communications. However, there is no guarantee that interference will not occur in a particular installation. If this equipment does cause harmful interference to radio or television reception, which can be determined by turning the equipment off and on, the user is encouraged to try to correct the interference by one or more of the following measures:

- Reorient or relocate the receiving antenna.
- Increase the separation between the equipment and receiver.
- Connect the equipment into an outlet on a circuit different from that to which the receiver is connected.

Consult the dealer or an experienced radio/TV technician for help.

Network Configuration

General Information

The **MP 8** can be operated in wired LAN networks (*Ethernet LAN* or *Powerline LAN*) or in wireless networks (*WLAN*).

If you wish to use your **MP 8** in your home network, you must first enter the necessary network settings on the **MP 8**. This includes entering the network parameters such as the IP address etc. both for wired and wireless operation. If you wish to use a wireless connection, a number of additional settings for the WLAN network also have to be entered.



In the following sections we assume that a working home network (cable network of WLAN network) with router and (DSL) Internet access is present.

If you are unclear about some aspect of installing, setting up and configuring your network, please address your queries to your network administrator or a network specialist.

Compatible hardware and UPnP servers

The marketplace offers a vast number of routers, NAS devices and USB hard discs made by a very wide range of manufacturers. **T+A** equipment is generally compatible with other makes of machine which bear the UPnP label.



Network settings menu



All network settings are entered in the Network Configuration menu. This menu will vary slightly in appearance depending on the type of your network, i.e. whether you have a wired (LAN) or wireless (WLAN) network.

If in the Network Configuration Menu the entry 'Network IF Mode' is set to 'auto', the **MP 8** will check automatically if a LAN connection to a network is present. If a LAN connection is found, the machine will assume that this is to be used, and displays the network configuration menu for LAN networks.



If no LAN network is connected, the **MP 8** activates its WLAN module and displays the WLAN configuration menu when you call up the configuration menu. The menu for a WLAN network includes a number of additional menu points. The following sections explain how to use the menu, and the meaning of the individual menu points.

Opening the network settings menu



Open the System Configuration menu by pressing the  button on the front panel or the  button on the remote control handset.

Use the  /  buttons to select the "Network" menu item, then confirm by pressing the  button.

Operating the menu, changing and storing IP addresses

Use the  /  buttons in the menu to select the network parameter to be changed, and activate the entry with the  button.

You can now change the setting using the following buttons, depending on the type of setting:



 /  button for simple selection (ON / OFF)



 /  and  /  buttons for entering IP addresses

 /  and  /  buttons for entering text

When the setting process is complete, or when you have entered the complete address, press the  button to confirm your action.

Alpha-numeric entry

At certain points, e.g. for entering server names or passwords, it is necessary to input series of characters (strings). At such points you can enter letters, numbers and special characters by repeatedly pressing the  /  buttons on the **FM8** remote control handset.

Press the  /  buttons on the remote control handset: repeatedly until the desired letter appears on the screen. Briefly press the  button to enter the next letter.

Press the  button to erase any letter.





Use the blue  button for toggling between numbers, capitals and lower-case letters. The bottom line of the screen shows which input mode is currently selected.

 At certain points (e.g. DNS server name) it is possible to enter both an alpha-numeric string and an IP address. At these points an IP address should be entered like a string (with separating dots as special characters). In this case an automatic check for valid address ranges (0 ... 255) is not carried out.

Closing the menu

Once you have correctly set all the parameters, select the menu item **'Store and exit?'**, then press the  button. This action causes the **MP 8** to accept the settings, and you should see the available network media sources (Internet radio, UPnP-AV server, etc.) displayed in the main menu.

Interrupting the menu without storing the settings

At any time you can leave the network configuration menu without making any changes to the network settings: this is done by pressing the  button, which takes you to the menu item **'Store and exit?'**. If you wish to quit at this point without saving, use the  /  buttons to select the **'Discard and exit?'** menu item, then confirm with the  button.

The Configuration for a Wired Ethernet LAN or Power-Line LAN connection

Setting the Parameters for a Wired Network

- Connect the **MP 8** to an operational network or Power-Line modem using the LAN socket on the back panel.
- Open the System Configuration menu by pressing the **sys** button on the remote control handset or the front panel of the **MP 8**.
- Use the **▲** / **▼** buttons to select the **"Network"** menu point, then confirm by pressing the **OK** button.
- You should now see the menu reproduced below, displaying the network parameters. In the title line the message 'LAN' should appear, indicating that the machine is connected to a wired LAN. If you see 'WLAN' at this point instead, please check your network connection, and ensure that the network is switched on and operational.
- You can now select the individual menu points and adjust them to match your network conditions. The illustration below shows the possible button inputs after each menu item.

Network settings menu		Possible entries
MAC	00:0e:9b:cc:a4:35	none
Connection state	LAN	none
→ DHCP	Off	◀ / ▶
IP	192.168.0.10	(0 ... 9)
Subnet mask	255.255.255.0	(0 ... 9)
Gateway	192.168.0.1	(0 ... 9)
DNS	192.168.0.1	(0 ... 9, A ... Z)
Store and exit?	apply	OK
Discard and exit?	apply	OK

- ◀** / **▶**: Switching ON / OFF
 (0...9): Numeric input, separating dots are automatically generated; input limited to valid addresses
 (0...9, A...Z): Alpha-numeric input and special characters.





IP - separating dots must be entered as special characters.







- i** The parameters illustrated above are only typical values. Addresses and settings may require different values for your network.

Menu Point	Description
MAC	The MAC address is a hardware address which uniquely identifies your machine. The address displayed is determined by the manufacturer, and cannot be altered.
Connection state	Shows the connection state: WLAN, LAN or not connected.
DHCP	<p>ON If your network includes a DHCP server, please select the ON setting at this point. In this mode an IP address is automatically assigned to the MP 8 by the router. The screen shows only the MAC address and the message DHCP state ON. In this case the address input fields shown in the illustration do not appear in the menu.</p> <p>OFF If your network does not include a DHCP server, please select the OFF setting. In this mode you must configure the following network settings manually. Please ask your network administrator for the addresses to be entered for your network.</p>
IP	IP address of the MP 8
Subnet mask	Network mask
Gateway	IP address of the router
DNS	Name / IP of the name server (optional)
Store and exit?	Stores the network parameters, and restarts the MP 8 with the new settings.
Discard and exit?	Closes the menu: data already entered is discarded.

The Configuration for a WLAN connection





Setting the parameters for a wireless network

- Disconnect a possibly connected LAN-cable.
- Now switch the **MP 8** on, and open the System Configuration menu by pressing the -button on the remote control handset or the -button on the front panel of the **MP 8**.
- Use the  /  buttons to select the menu point “**Network**”, then confirm your choice with the  button.
- The following menu now opens:

Network settings menu		settings
MAC	00:0e:9b:cc:a4:35	none
Connection state	not connected	none
→ WPS Autoconnect	apply	
Scan for WLAN	apply	
DHCP	Off	 / 
IP	192.168.0.10	(0 ... 9)
Subnet mask	255.255.255.0	(0 ... 9)
Gateway	192.168.0.1	(0 ... 9)
DNS	192.168.0.1	(0 ... 9, A ... Z)
Store and exit?	apply	
Discard and exit?	apply	

Selecting and connecting a WLAN by hand

Searching for and Selecting the Network

- First select the menu point “**Scan for WLAN**”, and activate it by pressing the  button.
- A list of the WLANs found is displayed on the screen.
- Use the  /  buttons to select the WLAN to which you wish the **MP 8** to be connected, and confirm your choice with the  button

Entering the Password (for encoded networks)

If the network is encoded, the window shown below will appear once the WLAN is selected.

At this point please enter the network passphrase and confirm your input by pressing .

Select the “Store and exit?” point, and confirm your choice with

.

Network settings menu		settings
SSID:	Name of the WLAN	none
Login:	Man. (WPA/WPA2)	none
→ Passphrase:	xxxxxxx	(0 ... 9, A ... Z)
Store and exit?	apply	

Storing Network Settings and Restarting





Finally select the “**Store and exit?**” menu point and press the  button to accept the settings.

Connecting to WLAN via the WPS-function

WPS-function





The **MP 8** supports WPS for WLAN setup. WPS (Wi-Fi Protected Setup) an easy process for establishing a secure WLAN connection. WPS can be used to connect the **MP 8** with your router in a quick and convenient way. For that usage most modern routers have implemented the WPS function.

Connecting WLAN automatically via the WPS function

- First activate the WPS-function of the Router or Repeater to which you wish the **MP 8** to be connected. For details please refer the manual of the device in question.
- Start the WPS-Autoconnect function of the **MP 8** within 2 minutes.
- Use the  /  buttons to select the menu point “**WPS-Autoconnect**”, then confirm your choice with the  button.
- After the connection is established, the line “Status” shows the connected WLAN network.
- Finally select the “**Store and exit?**” menu point and press the  button to accept the settings.

Selecting the WLAN manually and connecting via WPS

If the WPS function connects the **MP 8** to the wrong WLAN, the preferred WLAN can be also selected manually and only the authentication can be done by the WPS function. The procedure is described in the following:

- First activate the WPS-function of the Router or Repeater to which you wish the **MP 8** to be connected. For details please refer the manual of the device in question.
- First select the menu point “**Scan for WLANs**”, and activate it by pressing the  button.
- A list of the WLANs found is displayed on the screen.
- Use the  /  buttons to select the WLAN to which you wish the **MP 8** to be connected, and confirm your choice with the  button

- Select the “**Login**” menu point and press the button to activate it. Now select the setting „**Auto (WPS)**“ and confirm it with the button.
- Now select the “**Store and exit?**” menu point and press the button.
- After the connection is established, the line “Status” shows the connected WLAN network.
- Finally select the “**Store and exit?**” menu point and press the button to accept the settings.

WLAN setup via access point

The **MP 8** supports setting up the WLAN connection via an access point. This means that the **MP 8** provides its own WLAN for the duration of the configuration of the WLAN settings. As soon as the configuration is complete, this WLAN is deactivated again. The **MP 8** restarts and connects to the WLAN configured via the app.

- Turn on the **MP 8** and open the system configuration menu by pressing the button on the remote control.
- Use the / buttons to select the menu point “Network”, then confirm your choice with the button.
- Use the / buttons to select the menu point “Access Point”, then confirm your choice with the button.
- The **MP 8** activates the WLAN access point..
- The following steps must be performed within approximately 5 minutes. After this time, the **MP 8** will exit Access point mode automatically.
- Connect the smartphone or Tablet PC on which the **T+A**-App is installed to the WLAN access point. The network name (SSID) is "T+A AP **MP 8** " and the passphrase is "01234567".
- Start the **T+A** -App for operation.
- The app recognizes the access point and starts automatically with the setup wizard.
- To set up the WLAN, go through the individual steps of the app's setup wizard.
- Quit the app, then connect your phone or tablet to your previously set up wireless LAN.
- After restarting the app the **MP 8** will be detected automatically.
- Once the **MP 8** is detected, it can be selected for playback.

Trouble shooting

Many problems have a simple cause and a correspondingly simple solution. The following section describes a few difficulties you may encounter, and the measures you need to take to cure them. If you find it impossible to solve a problem with the help of these notes please disconnect the unit from the mains and ask your authorised **T+A** specialist dealer for advice.

Machine does not switch on	Cause 1: Mains lead not plugged in correctly. Remedy: Check connection, push connector in firmly.
Machine cannot be controlled by IR remote control.	Cause 1: The integrated battery of the FM8 is empty. Remedy: For charging connect the FM8 to the USB IN socket of the MP 8 . Cause 2: The remote control transmitter has no direct line-of-sight with the unit. Remedy: Make sure that the remote control transmitter has direct line-of-sight contact with the receiver - note that glass doors can interrupt the connection. Maximum range between transmitter and receiver: approx. 8 metres. Be sure to position the receiver where it is not subjected to direct sunlight or very bright artificial light. Fluorescent tubes and energy-saving lamps are powerful sources of interference.
App cannot find the device in powered off state.	Cause: Energy saver is switched on. Remedy: Switch off the Energy saver function in the system configuration menu.
The streaming client cannot connect to a network. On the display the indication 'Cannot connect to network' is displayed.	Cause 1 (cable LAN): Network cable not properly connected Remedy: Connect network cable, check connection to router Cause 2 (wireless LAN): WLAN antenna not connected or placed in a location with bad reception quality Remedy: Connect WLAN antenna properly and find a location with good reception quality. Set the transmission power output of your WLAN router to maximum. Try to establish a network connection first in a location close to the WLAN router. If this succeeded try to connect to WLAN from a more remote location. Experiment with antenna position and try to find a location with better reception quality.

Cause 3 (wireless LAN):

WLAN reception quality bad (low field strength). Possibly too much attenuated by walls/ceilings on the transmission path.

Remedy:

Optimize location of receiver and transmitter antennas.

Alternative:

If transmission problems persist a so called 'Power Line' network might be good alternative to establish a good and stable network connection.

The best, safest and most secure network however will always be a cable LAN network.

Cause 4:

Network parameters not properly configured.

Remedy:

Configure the network parameters correctly (see chapter '**Network configuration**').

Cause 5 (operation without network connection):

For proper operation the **MP 8** needs at least one properly connected network device. This can be a LAN or WLAN network or a USB storage device.

Remedy:

If the **MP 8** shall be operated without network (LAN / WLAN) please connect at least a USB stick.

The device does not work correctly in combination with the DAC 8 DSD.

Cause 1:

The SYS connection between the two devices is not established correctly.

Remedy:

Connect the SYS-Out socket of the **MP 8** to the SYS-In socket of the **DAC 8 DSD**.

Cause 2:

The **DAC 8 DSD** requires at least software version 2.60 for operation with the **MP 8**.

Remedy:

Update the **DAC 8 DSD**.
(see chapter "Software update")

Software update

Software update generally

For updating the firmware of the **MP 8** there is a convenient method which requires an existing Internet connection

If you are operating the **MP 8** in conjunction with a **DAC 8 DSD**, the machine can also be updated via the **SYS** connection.

The wiring diagram for the machines is shown in '**Appendix A**'.

The following section describes the exact method of updating the firmware in detail.

i For a correct function together with the **MP 8**, the **DAC 8 DSD** must have at least software version **V2.60** installed.

If no software version is displayed in the update menu, an update should be carried out in any case.

Updating via the Internet

- The basic requirement is a functioning network with router and access to a broadband Internet connection; the system must be operating.
- Switch the machine on.
- Call up the System menu by pressing the **SYS** button on the **MP 8**'s front panel or the **FM8** button.
- Use the **▲** / **▼** buttons to select the **"Device info"** menu item, and confirm your selection by pressing the **OK** button.

- If the **MP 8** is connected to a **DAC 8 DSD** via the **SYS** connection, the Select Device menu appears at this point. In this case select the device to be updated and confirm your choice by pressing the **OK** button.

(If the **MP 8** is not connected to a **DAC 8 DSD**, the Software Update menu of the **MP 8** appears directly.)

- Select the **"Update"** menu item with the **▲** / **▼** buttons to and confirm your selection by pressing the **OK** button.
- The Select option **"WEB"** should now be active (highlighted).
- The firmware update can now be started by pressing the **OK** button.
- The screen displays the current state of progress of the update.
- Once the update has been completed (duration around ten minutes) the device automatically switches itself off and restarts.
- When the machine has restarted, the update is complete.
- To ensure that the update was successful, access the **"Device Info"** menu point mentioned above, and check the new firmware status.

Notes on Energy Saving

General information

The **MP 8** satisfies the requirements of the latest directives concerning energy-saving measures (EuP directive). The modern design of the mains power supply makes an important contribution to this.

The internal micro-processor constantly ensures that sub-assemblies which are not currently required are automatically switched off. The micro-processor itself operates in stand-by mode at a relatively low clock speed, and only responds to the remote control receiver.

In stand-by mode the current drain of the **MP 8** is less than 0.5 Watt.

If you intend not to use the device for a long period, it should be disconnected from the mains socket, i.e. the mains plug should be withdrawn from the wall socket.

Automatic power-down (Energy saver)

The device features an automatic power-down function. If the **MP 8** detects no operation or no music signal for a period longer than ninety minutes, it automatically switches to stand-by mode. Two minutes before the device enters the standby mode, a pop-up window appears on the screen. If the device should stay in operation please press the  button while this message is displayed.

 In countries outside the EU, in which the EuP directive has no validity, the automatic power-down feature can be disabled if necessary (see chapter entitled "Basic settings of the **MP 8**").

Legal Information

General information



This product contains software in form of object code that is partially based on free software under different licenses. Details of the licenses used can be viewed on the device website using an Internet browser.

Show licenses

To access the device website, enter the IP address of the device and "/licenses/" in the address line of the browser you are using.

For example <http://192.168.178.100/licenses/>

You can display the exact address as follows:

- Call up the system configuration menu by pressing the  button.
- Then navigate to the "Device Info" menu item. Open it by pressing the -button.
- Navigate to the menu item "Legal information" and open it with the -button.

The pop-up window that now opens shows the address of your device.

 The address is only displayed in the pop-up window if the device has a correctly configured network connection. For details on network configuration, see the "Network Configuration" section.

To view the web page of the **T+A** device, the device on which the Internet browser is started must be connected to the same network as the **T+A** device.

Appendix A

Wiring diagram

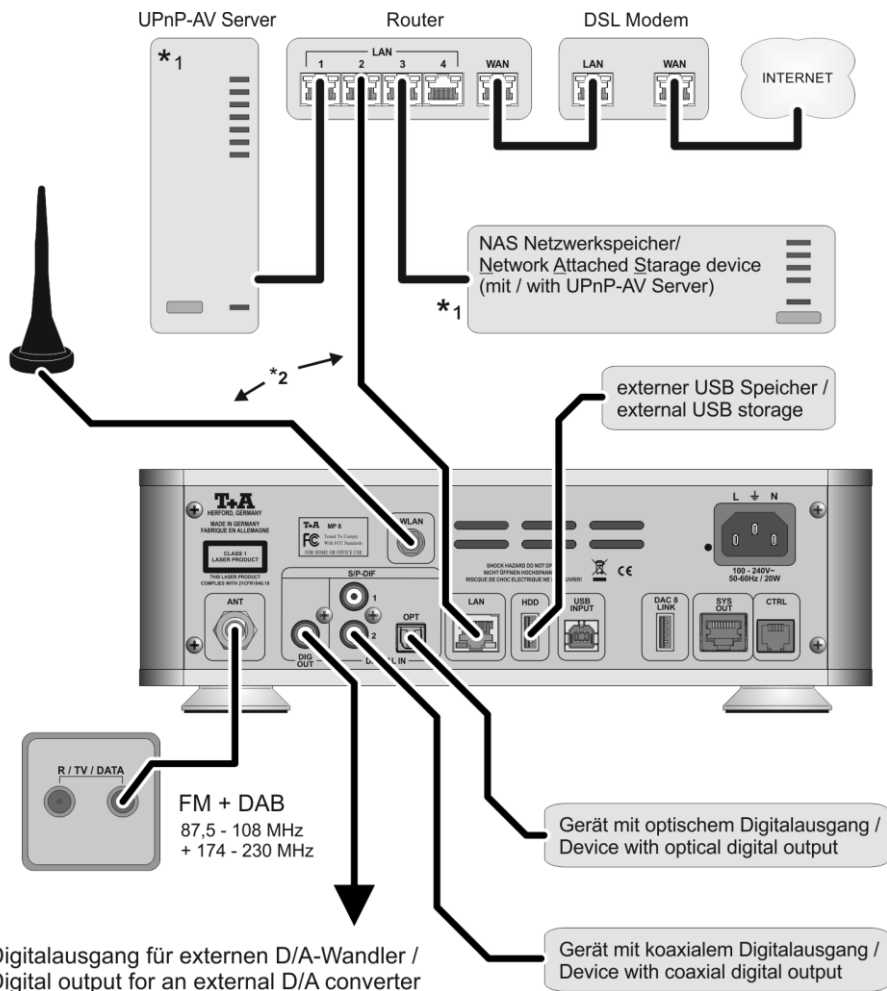

Attention!

A properly set up home network with router must be installed and in operation to use the **MP 8**. For the use of internet radio a DSL access to the internet is needed.

For questions regarding setting up your network and internet connection please ask your system administrator or any network specialist.

*1 Music server with UPnP-AV server software installed

*2 Connection either via Cable-LAN or Wireless-LAN

Wiring diagram

Windows oder MAC Computer /
Windows or MAC Computer

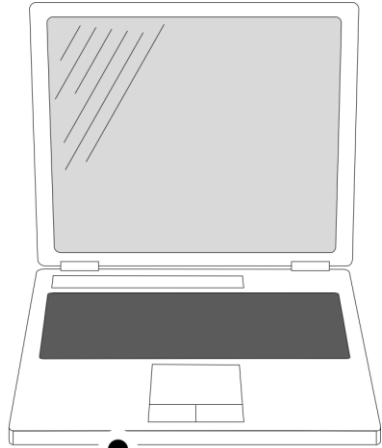

MP 8

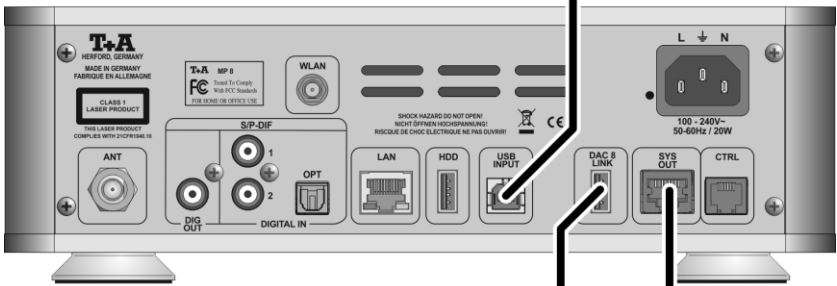

DAC 8 DSD

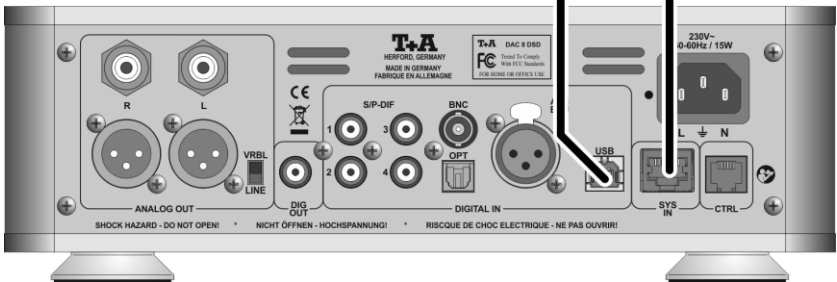

Appendix B

Specification

CD Player	
Formats	CD/DA,CD-R, CD-RW / CD-Text
Frequency response	2 Hz - 20 kHz/100 dB
Streaming Client	
Formats	MP3, WMA, AAC, AIFF, OGG-Vorbis, FLAC + WAV
Data rates	PCM 32...192 kHz,16/32 Bit; MP3 up to 320 kBit; constant and variable data rate
Services	Tidal, Deezer, qobuz (subscription required)
Media server	UPnP AV, Media Player 10 (WMDRM10), DLNA compatible servers
Interfaces	LAN: Fast Ethernet 10/100 Base-T, WLAN: 2,4 GHz, +20 dBm (100 mW), IEEE 802.11 b/g/n
Bluetooth	
	A2DP Bluetooth audio transfer protocol with AVRCP
Formats	MP3, AAC, SBC
Frequency band	2,4 GHz
Max. transmit power	+4dBm (2,5 mW)
USB	
	2x USB 2.0 Mastermode
Radios	
Internetradio	airable Internet Radio Service (> 11000 Stations worldwide)
FM, FM-HD	87,5 - 108 MHz; Empfindlichkeit 1 µV; S/N > 65 dBA
DAB, DAB+	168 -240 MHz (Band III); Sensitivity 2,0 µV, S/N > 96 dBA
Features	RDS/RDBS, Station name (PS), Program type (PTY), Radiotext (RT), Clock

Connections	
Inputs	SP/DIF (16-24bit): 2x coax (192kHz), 1x TOS-Link (96kHz)
Outputs	Coaxial digital output (IEC 60958), DAC 8 LINK USB-Output
Power requirement	100 – 240 V, 50 – 60 Hz
Power consumption (max.)	20 W
Standby (ECO)	0,5 W
Auto power off function	Yes (after 90 minutes without audio signal)
Dimensions (WxHxD)	27 x 9 x 27 cm
Weight	4 kg
Accessories	Remote control FM8, USB A/Micro cable for charging the FM8, WLAN antenna, SYS-Link cable, USB A/B cable for connecting the DAC 8 DSD, user manual

We reserve the right to alter specifications.



T+A elektroakustik GmbH & Co. KG
Planckstraße 9 – 11
D - 32052 Herford

T +49 (0) 5221 / 7676-0
F +49 (0) 5221 / 7676-76

info@ta-hifi.com
www.ta-hifi.com