

MAIN FEATURES

- FAMILY FEELING :**

A visible reminder of the Olympica Nova collection is the leather that embellishes the shape around the tweeter.

- SOUND POINTING :**

Whenever front speakers cannot be placed on walls, this model is made to be mounted in the ceiling. By positioning drivers to be angled to the surface, the sound emission aims to the direction of the listening position.

- MAGNETIC GRILLES :**

The PC-662P is equipped with a magnetic edgeless round metal grille, ready to be painted. The square metal grille is optionally available.

- QUICK INSTALLATION :**

Thanks to the swing out dogs fixing system, all Palladio speakers can be secured quickly and effectively to plasterboard.

- PRE-MOUNT KIT :**

If the PC-662P must be installed in a new construction, a pre-mount kit is provided as an optional accessory.

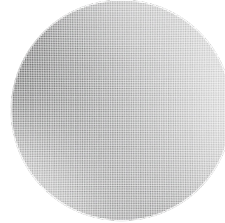

magnetic round metal grille

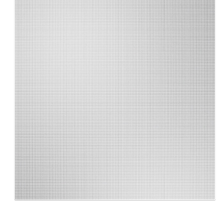

magnetic square metal grille

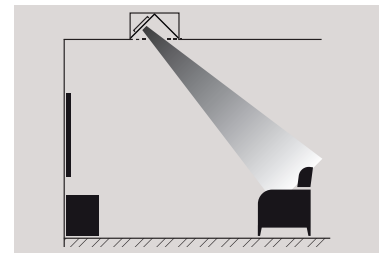

sound pointing

TWEETER :
DAD™ (Damped Apex Dome) silk dome tweeter.

MID-WOOFER :
The custom diaphragm is made in natural fiber and cellulose pulp, according to the most natural sound



PARACROSS TOPOLOGY™
The anti-resonant design of the x-over network features the Paracross Topology™ circuitry enriched with custom made capacitors branded by Sonus faber.

LOUDSPEAKER SYSTEM	2-way point in ceiling system. Infinite baffle.
TWEETER - DAD™ DRIVER	29 mm / 1.1 in
MIDWOOFER	165 mm / 6.5 in
CROSSOVER FREQUENCY - PARACROSS TOPOLOGY™	3,000 Hz
FREQUENCY RESPONSE	50 - 25,000 Hz (-6dB)
SENSITIVITY (2.83 Vrms @ 1m)	90 dB SPL
NOMINAL IMPEDANCE	4 Ω
SUGGESTED AMPLIFIER POWER OUTPUT (*)	40 – 200 W Undistorted signal
FRAME OUTER	Ø 265 mm / 10.4 in
CUT OUT	Ø 244 mm / 9.6 in
DEPTH BEHIND SURFACE	172 mm / 6.8 in
PROTRUSION	10 mm / 0.40 in
NET WEIGHT	3,83 kg / 8.44 lb
INCLUDED IN THE BOX	Bezel-Free round magnetic grille
ADDITIONAL FITTINGS	Pre-mount kit 0,34 kg / 0.74 lb
	Bezel-Free square magnetic grille 0,44 kg / 0.97 lb 287x287 mm / 11.3 x11.3 in

(*) See instruction's manual for more information

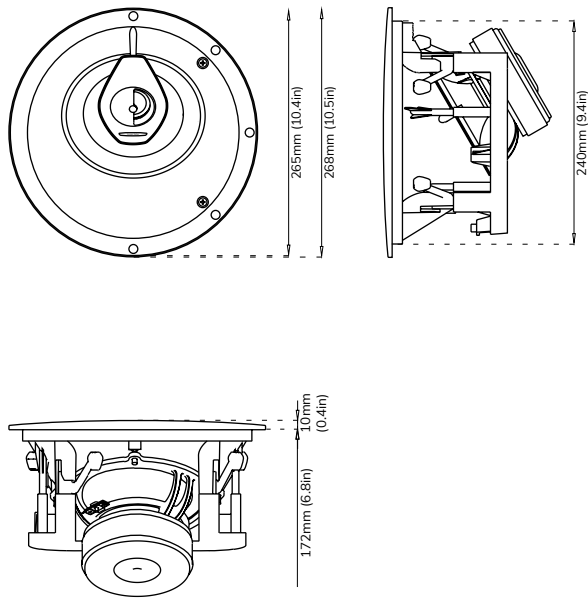

IMPEDANCE
GENERATOR LOAD IMPEDANCE
GENERATOR LOAD PHASE

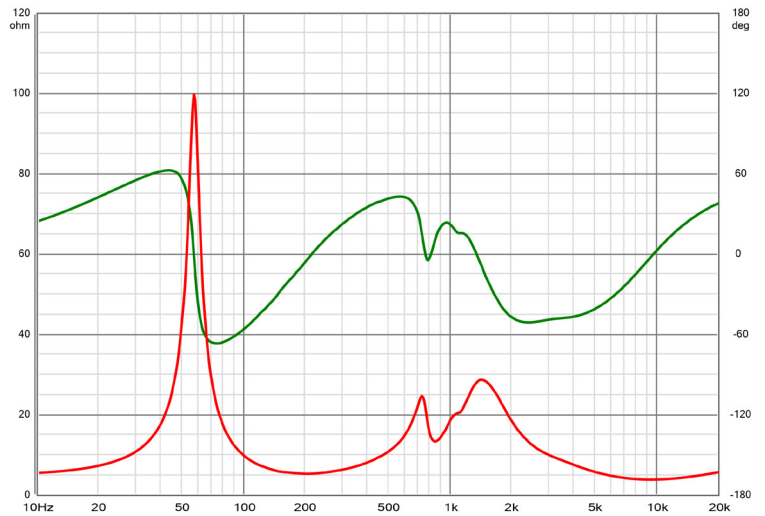

AMPLIFIER OUTPUT POWER REQUIREMENTS VS. LISTENING DISTANCE (PER SINGLE CHANNEL) *

	LISTENING DISTANCE [m]						
	1.50	1.75	2.00	2.50	3.00	3.50	4.00
W CONTINUOUS	1.4	1.9	2.5	4	5.7	7.8	10
W PEAK	2.9	3.9	5.1	7.9	11.4	15.5	20

* [FOR A DIRECT SPL=85 dB; 1 kHz SINE TONE]

	LISTENING DISTANCE [m]						
	1.50	1.75	2.00	2.50	3.00	3.50	4.00
W CONTINUOUS	11.3	15.4	20.1	32	45	62	80
W PEAK	45	60	80	125	180	246	320

* [FOR A DIRECT SPL=85 dB; IEC TEST SIGNAL SIMULATING A NORMAL PROGRAM]

The huge difference between the values depends on the signals that have been considered in the two examples. A simple sine tone is the most elementary one while the IEC signal is quite complex. In a real world, while the first could conveniently represent the power needs for speech, the second gives an idea of the power needs for wide frequency range, large headroom music.

HORIZONTAL DISPERSION [@1m WITH 2.83 VRMS]

--- 45°; --- 0°

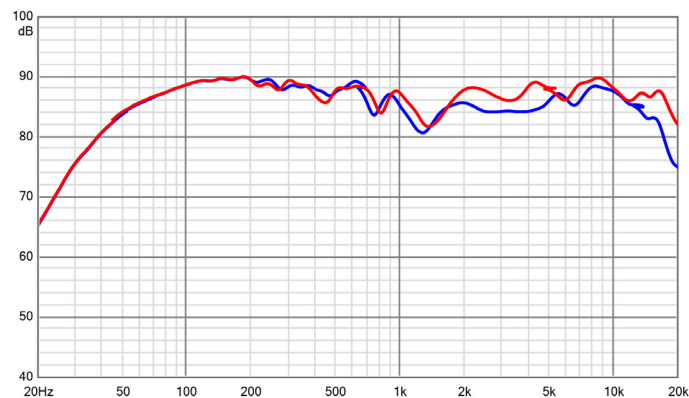

VERTICAL DISPERSION [@1m WITH 2.83 VRMS]

--- 45°; --- 0°

