

A4.2. DOLBY ENABLED SPEAKERS

OPERATING INSTRUCTIONS

Safety Instructions

1. General information

- Please read and follow these safety instructions.
- Keep them safe for future reference.
- Observe all warnings on the speaker and in the manual. Please check the speaker for damage before use. The speaker must be in perfect working condition. Damaged parts may lead to personal injury.

CAUTION! Subwoofers and active speakers are heavy. Be careful when lifting them to prevent personal injury.

2. Use only as directed

- Connect the speaker(s) according to the instructions in the manual.
- Many ELAC speakers are equipped with spikes and/or anti-slip feet. They are explicitly provided for levelling the alignment. They have to be screwed into the thread until thread end. For levelling on an uneven floor, it is allowed to unscrew the spikes or anti-slip feet by 2-3 turns of thread. The speaker should always be in perfect vertical alignment. The stability of the speaker must not be compromised by using spikes or anti-slip feet as the speaker may tip-over.

3. Location

- Install the speakers on a level surface only
- When choosing the location of these speakers do not place them in locations that are:
 - In direct sunlight
 - Very humid
 - Prone to vibrations
 - Exceptionally hot or cold
 - Near CRT Televisions (the speakers are not magnetically shielded and may cause color issues with a CRT based TV)
 - Close to magnetic cards (Since the speakers are not magnetically shielded placing magnetic cards such as credit cards or commuter cards may cause them to fail).

WARNING! Please ensure the product is perfectly stable to avoid severe injury from tip-over. Please note, that stability can be increased by using spikes on carpeted surfaces. However, the mounting of spikes must be carried out carefully due to their very sharp ends which may cause injuries. The stability on slippery floors can be increased by using Velcro fastening tape or double-sided adhesive tape. Do not install the speaker near any heat sources such as radiators, heating valves, stoves, or other apparatus (including amplifiers) that produce heat, or in areas where there is a risk of explosion.

- Do not block any ventilation openings. Install in accordance with the manufacturer's instructions.
- Don't install the speaker in a closed rack or in a closed cupboard.
- Don't put burning candles on or near the speaker.
- Do not install the speaker near transformers because electromagnetic stray fields can cause hum noise on woofers.
- In combination with certain materials / lacquers / material surfaces, anti-slip feet or spike washers may cause colored imprints on the surfaces.

4. Overload

Extreme overload of the device due to very high volume may cause damage to individual components. Theoretically, this kind of overload could cause a fire inside the cabinet (although no actual case is known). Because of the possible danger, you should never leave loudspeakers under extreme overload conditions unattended.

5. Service

DANGER! Do not open the cabinet because the components and conductors may carry current! Servicing to be carried out by qualified service personnel only.

Servicing is required when the loudspeaker has been damaged in any way, such as damage to the power supply cord or the plug, or when liquid has been spilled or objects have fallen onto the loudspeaker, the speaker has been exposed to rain or moisture, does not operate normally, or has been dropped. To reduce the risk of electric shock, do not open the loudspeaker. Servicing should be carried out by qualified service personnel only.

6. Cleaning

NOTE: Clean only with soft, smooth cloth or with dust brush. Do not use scouring agents, alcohol, benzene, furniture polish or other agents for cleaning! Modern furniture is often coated with multiple varnishes and plastics which can be treated with chemical agents. Some of these agents contain substances which degrade or soften the rubber feet. Therefore we advise that you place an anti-slip mat underneath the loudspeaker(s).

7. Volume

CAUTION! Continuous high volume may cause severe damage to your hearing. Please listen responsibly.

8. Disposal

The packaging is made from recyclable materials. Dispose of this in an environmentally friendly manner. At end of life do not dispose of the speaker(s) with standard household waste. The speaker must be recycled in accordance with local legislation. Ask your local government for further information on recycling as the device contains valuable raw materials. Disable the speaker(s) before disposal.

Philosophy

Thank you for purchasing this ELAC product.

When we started in 1926, ELAC has always strived to achieve the very best. This holds true as much today as it did back then.

Your new ELAC speakers are built to the highest standards using high-quality components that are carefully constructed to deliver the best-in-class sound quality. They are developed by a passionate group of individuals whose soul purpose is to bring a new dimension of sound quality into your home. Enjoy!

Before Use

Avoid damage to the speakers and other components:

- Unbox the speakers carefully to avoid physically damaging your speakers.
- Use appropriate gauge wires (minimum of 16 gauge wire for runs up to 25 feet).
- Make sure wire polarity is connected correctly. Most speaker cables are coded for ease of use. Make sure positive (red) connection on the amplifier terminal is connected to the positive (red) on your speakers. Follow the same instructions for the negative side. Strip off approximately 1/2" of the insulation from the ends of the speaker cable, twist the bare strands and insert into the binding post.
- **The A4.2 speakers are specifically designed for use as Atmos Enabled speakers. They cannot be used as traditional speakers. Doing so will damage the speakers.**
- Keep your equipment turned off before connecting speakers.
- Check to ensure positive and negative wires are not touching each other once they're connected to the speaker terminals.

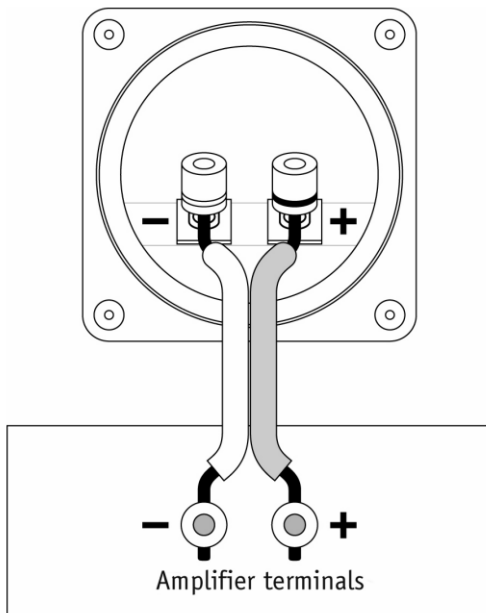

A4.2 Dolby Atmos Speakers

Dolby Atmos

Dolby Atmos is the newest technology that brings a third characteristic into the home theater audio environment — height. This revolutionary technology is now being encoded into many of the latest movies and videos to fully deliver an immersive audio experience like no other.

Unlike the traditional home theater experience where content is mixed into channels, Dolby Atmos is mixed as audio objects. This means the technology adapts to the configuration of your speakers giving you the ability to have a variety of different speaker configurations of five speakers on the floor and two speakers producing overhead sound to as many as 24 speakers on the floor and 10 speakers producing overhead sound.

With the ELAC A4.2 speakers, you will not need to install speakers into the ceiling. However, your room will need to be of basic shape, size, and with ceilings of certain height.

Together with a Dolby Atmos enabled receiver, ELAC Debut speakers and the A4.2 add-on Dolby Atmos speakers, you'll be in the middle of an amazingly effective 3-dimensional audio experience. The A4.2 speakers will provide the height sound without having to install ceiling speakers to get the Dolby Atmos effects.

Room Requirements

Placement

For optimal effect and to minimize direct radiating audio at listener level, place Dolby Atmos enabled speakers at or slightly above the height of your ears when seated. Avoid placing the Dolby Atmos enabled speakers higher than one-half the height of your wall.

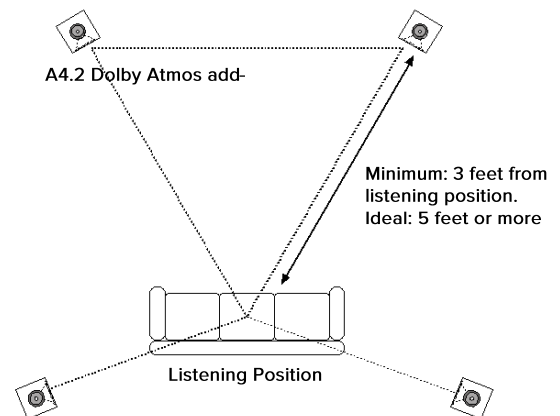

Room Height

For optimal performance, the ceiling should be flat (not angled or vaulted), with a height of 14 feet (4.27 meters) or less, and made of an acoustically reflective material (drywall, plaster, hardwood, or another rigid, non-sound-absorbing material). The ideal ceiling height is between 7.5 and 12 feet (2.3 and 3.66 meters). Sound-absorbing and sound-diffusing treatment for handling unwanted reflections from the walls and floor is recommended to improve sound quality and system performance.

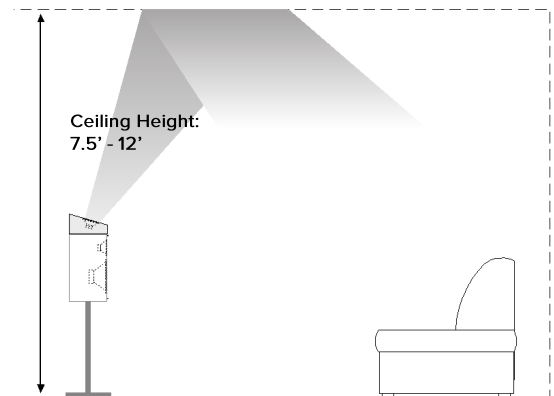

ELAC A4.2 Add-on Speakers

A4.2 DESIGN

The ELAC A4.2 Speakers were designed for the reproduction of the newest Dolby Atmos sound technology. They are optimized to match the ELAC Debut speakers in both sound quality and cosmetics but they can also be used with any brand of conventional bookshelf or floorstanding speakers in the market. The A4.2's construction and performance characteristics follows the strict guidelines set by Dolby in order to deliver to you a true Dolby Atmos experience.

The A4.2 is meant to sit on top of the Debut ELAC B5.2/B6.2 bookshelf or F5.2/F6.2 floorstanding speakers angled to project sound towards the ceiling. The reflected sounds reflected off the ceiling creates the height information embedded into Dolby Atmos titled sources and are mixed with sounds coming from the traditional 5.1 or 7.1 speaker set-up of your home theater system.

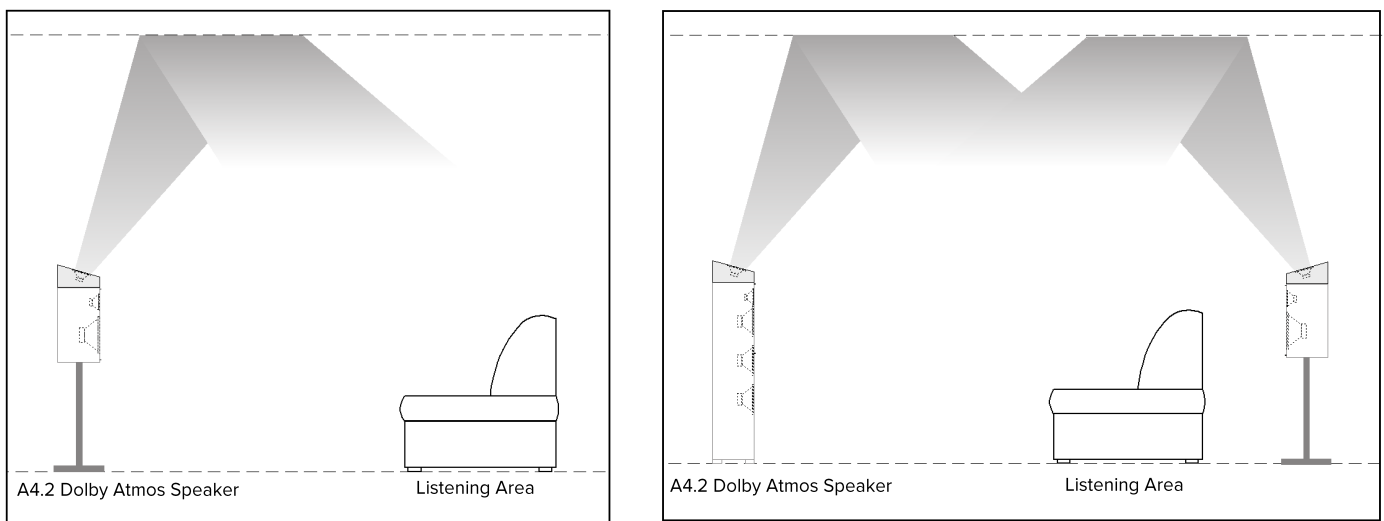

Connections

Follow the instructions for your Dolby Atmos AV Receiver for connection instructions. These will vary based on the manufacturer.

The A4.2 uses a concentric speaker design where a 1/2-inch tweeter resides in the center of a 4-inch midrange driver. The A4.2 speaker should be placed within ear level of the listener, preferably directly on top of your existing bookshelf or floorstanding speakers. The A4.2 should not be blocked by any object as the obstruction will greatly affect its performance and will degrade the effects it is trying to achieve.

Dolby Atmos Speaker Configurations

There are three basic Dolby Atmos configurations when using the A4.2 add-on speakers.

- 5.1.2 Setup - This configuration uses a pair of A4.2s in addition to your existing 5-channel speakers. The pair of A4.2s would be added to the front left and right speakers as height channels.
- 5.1.4 Setup - This configuration uses two pairs of A4.2s in addition to your existing 5-channel speakers. The A4.2 would be adding both front (left and right) and rear (left and right) as height channels.
- 7.1.4 Setup - This configuration uses two pairs of A4.2s in addition to your existing 7-channel speakers. The A4.2 would be adding both front (left and right) and rear (left and right) as height channels.

In all configurations, a set of A4.2 speakers is allocated to the front left and right speakers. The ideal position is directly on top of your existing speakers. In the event that the A4.2 cannot be placed on top of your speakers due to restrictions, place it within 2-3 feet of your left and right speakers. Additionally, the height should be as high as or within 18 inches above the left and right speakers.

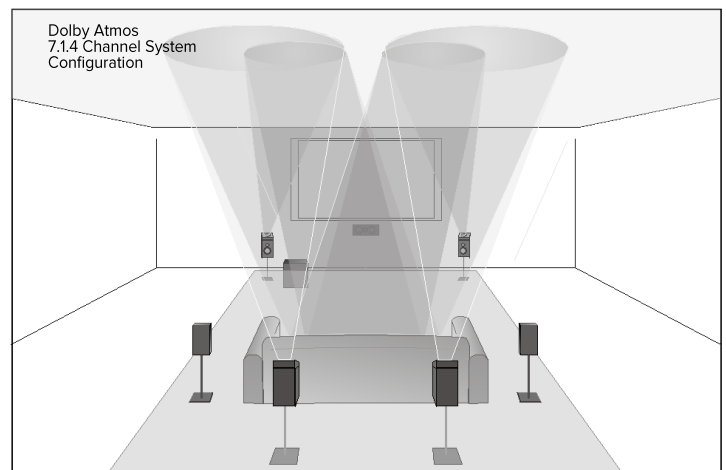
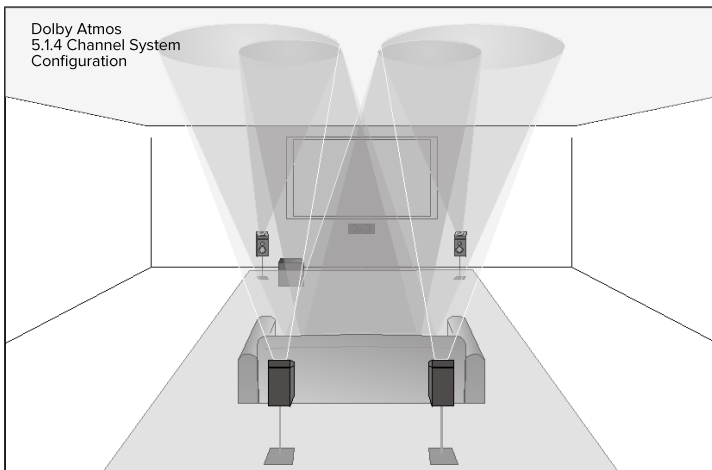

Side or Rear Application in a 5.1.4 or 7.1.4 system:

Place the A4.2 on top of the rear left and right speakers. If restricted, place them within 2-3 feet and the same height or at least 18 inches above or below the speakers.

If you need additional guidance on a more elaborate speaker setup or need more information on Dolby Atmos, please visit <http://www.dolby.com/us/en/technologies/dolby-atmos.html>.

Wiring/Level Setting:

Follow the receiver/amplifier instructions for appropriate wiring of the A4.2. When setting up and matching the output level, refer to the users manual of your receiver/amplifier. Complete the setting based on the configuration of your system and the recommendations given by the receiver/amplifier manufacturer.

Caution: Overpowering may cause failure to the A4.2 speakers. Always be responsible when listening to your speakers at extremely high volume as they can cause hearing damage or loss.

SPECIFICATIONS

A4.2 SPECIFICATIONS

ENCLOSURE TYPE	SEALED
CONFIGURATION	2-WAY CONCENTRIC
WOOFER	4" ARAMID FIBER
TWEETER	1/2" POLYMER DOME
FREQUENCY RESPONSE	180—20000Hz
CROSSOVER FREQUENCY	2000Hz
MAXIMUM INPUT POWER	80 WATTS
SENSITIVITY	85db @ 2.83v/1m
NOMINAL IMPEDANCE	6 OHMS
MAGNETICALLY SHIELDED	NO
FINISH	BLACK ASH VINYL
WIDTH	7.09 INCHES / 180 mm
HEIGHT	4.92 INCHES / 125 mm
DEPTH	9.21 INCHES / 234 mm
WEIGHT (EACH)	5.5LBS / 2.5 kg

Manufactured under license from Dolby Laboratories. Dolby, Dolby Atmos, and the double-D symbol are trademarks of Dolby Laboratories.

ELAC Americas Inc.
North America Limited Liability Warranty
Passive Speakers (No Built-in Amplifier)

ELAC Americas Inc. warrants to the original purchaser that this product be free from defects and or workmanship for a period of 3 (Three) years from the original date of purchase. During this time period, repair or replacement of parts will be free of charge to the original owner (See below limitations). Shipping to and return from the repair center will be the responsibility of the original purchaser.

Limitations

- Warranty begins on the date of original purchase from an authorized ELAC Americas Inc. dealer.
- Product is warranted only if used in home applications within the max power rating specified in this manual. Commercial use of this product is not warranted.
- Product that has been modified or altered in anyway will not be warranted.
- Product that has been abused or subjected to faulty equipment will not be warranted.
- Products with defaced or removed serial numbers will not be warranted.

If service is required

In the event that service is required, please contact ELAC America at 888-541-0996 or at customerservice@elac.us to arrange for service or replacement. You will be responsible to provide proof of purchase (Copy or original sales receipt). Shipping to and from our repair center will be the responsibility of the original purchaser.

Warranty Outside of North America

This warranty applies to products purchased in the United States and Canada. For warranty claims outside of North America please contact the local dealer/distributor in the country of purchase.

ELAC The life of sound.

ELAC AMERICAS INC.
11145 KNOTT AVE. SUITES E & F
CYPRESS, CA. 90630

ELAC ELECTROACUSTIC GMBH
FRAUNHOFERSTRASSE 16
24118 KIEL, GERMANY